



---

## 82 Electrical system of body

---

Job No.

### Lamps

Removal and installation of dome lamps front and rear .....	82-010
<b>Adjusting lamps , front</b> .....	040
A. Preparations for adjustment .....	
<b>B. Main</b> headlamps .....	
C. Foglamps .....	
Removal and installation of lamp unit .....	052
Removal and installation of lamp unit bulbs .....	062
Removal and installation of lamp unit glass .....	067
Removal and installation of tail lamp unit .....	252
Removal and installation of license plate lamp .....	348

<b>Electric wiring diagram, heatable rear window</b> .....	<b>395</b>
--	------------

### Radio, speaker, antenna

Removal and installation of radio .....	505
Removal and installation of speaker, front and rear .....	512
Operation of automatic antenna (USA) .....	530
Removal and installation of antenna .....	535

### Wiping washing system

Removal and installation of profilated rubber or wiper blade .....	610
Removal and installation of wiper motor .....	680
Removal and installation of wiper linkage .....	760
Removal and installation of rubber seal under wiper gears ..	765
Electric wiring diagram of wiping-washing system .....	785
Windshield washer .....	<b>795</b>

### Seat heater

Operation of seat heater .....	<b>800</b>
Electrically adjustable outside rear view mirror .....	833
Outside rear view mirror with electrically heated plate glass .....	834
Electric wiring diagrams	
Electrical seat adjustment, front .....	<b>860</b>
A. Version without memory circuit .....	
B. Version with memory circuit .....	
Removal and installation of switch for electrical sea adjustment .....	865

### Anti-theft warning system (EDW)

Operation of anti-theft warning system (EDW) .....	<b>980</b>
<b>a) General</b> .....	
b) Electrical wiring diagrams .....	
c) Switching system on and off .....	
d) Layout of components .....	

**Dome lamp front**

**Removal**

---

- 1 Disengage holding spring of dome lamp at recess.
- 2 Slightly pull out dome lamps and remove toward the right.
- 3 Pull off electrical connections.

**Installation**

---

- 4 For installation proceed vice versa.

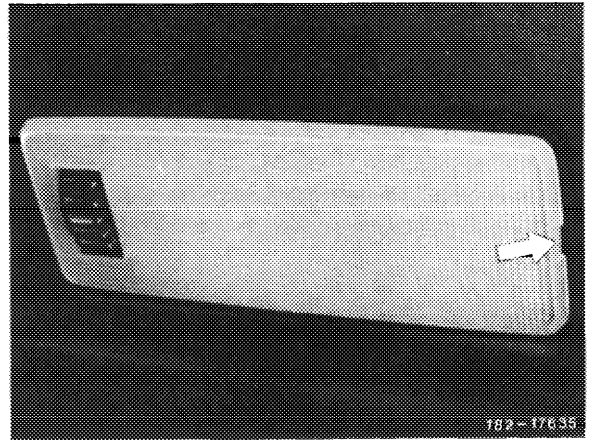

**Note:** The dome lamp of model 201.034 is equipped with an electronic cutout delay, a reading lamp is also installed, The time delay switch is installed in dome lamp. It cannot be separately replaced. After approx. 6 seconds the light is automatically switched off after the driver's door has been closed.

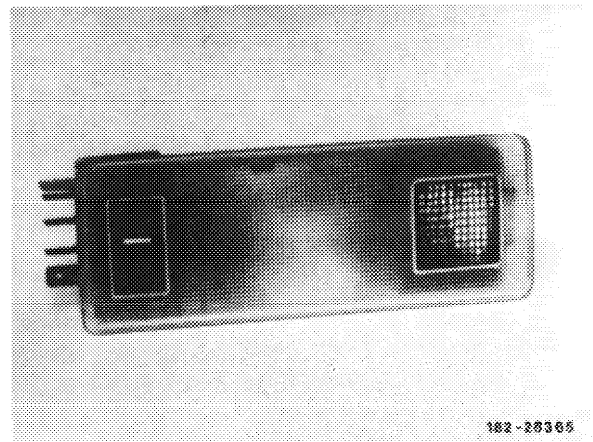

**Renewing bulbs**

Swing out reflector (1) and remove bulb.

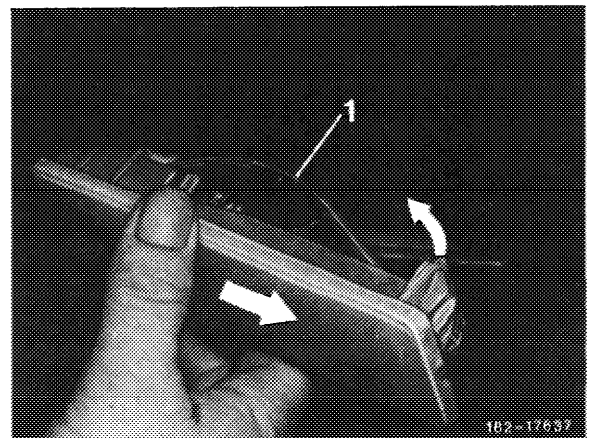

**Reading lamp: model 201.034**

Push contact rail in direction of arrow, rotate lamp, so that the bulb can drop out.

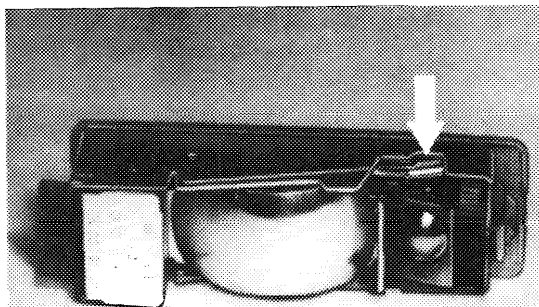

182-28366

**Dome lamp rear**

**Removal**

---

4 Disengage holding spring of dome lamp at recess. Slightly pull out dome lamp and remove toward the right.

5 Pull off electrical connections.

**Installation**

---

6 For installation proceed vice versa.

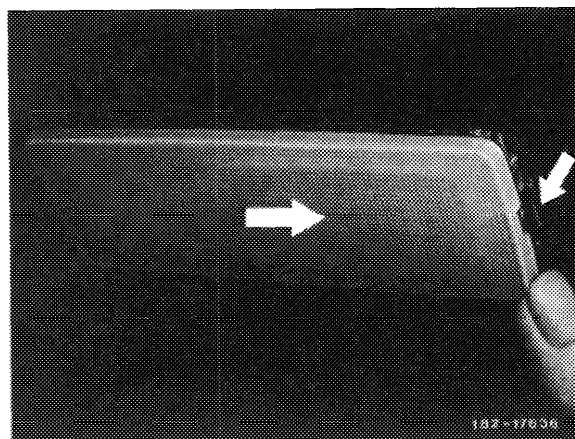

182-27056



**Adjusting table** (dimensions in cm for test area at a distance of 10 m from headlamps)

Type of vehicle	Load vehicle during adjustment as follows	Adjusting dimension "e" in cm	
		Main headlamps	Fog lamps
Passenger cars in which the upper reflector edge of headlamps is not more than 135 cm above vehicle base.	One person or 75 kg on driver's seat of the otherwise unloaded vehicle (curb weight*).	10	10

\* ) Curb weight is the weight of the vehicle ready for operation with completely filled, built-in fuel tank, including the weight of all the equipment carried along while driving (e.g. spare wheels and tires, replacement parts, tools, vehicle jack, fire extinguisher).

### A. Preparations for adjustment

For adjusting headlamps, place vehicle on level ground. Even a slightly irregular surface under vehicle may falsify adjustments. Keep inflation pressure on all tires as specified. Load vehicle according to data in adjusting table and drive slowly on adjusting surface so that the spring adjustment will not change when the brakes are applied.

Adjust headlamps individually by switching off or covering the other headlamps. Whenever possible, make adjustments in a closed room, in a fairly dark environment, since the accuracy of the adjustment can be influenced by wind (movements of test surface) and by other light sources. Use a headlamp adjusting device whenever possible. Proceed accurately according to pertinent instructions. If no headlamp adjusting device is available, adjust by means of an adjustable, level test surface.

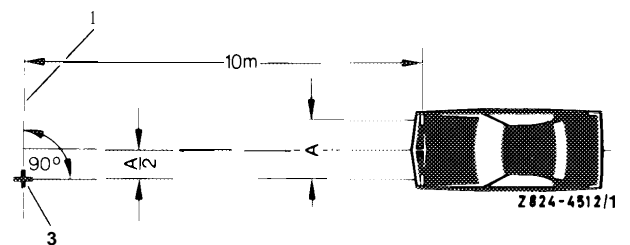

In an emergency, the test surface can also be drawn on a wall. The surface should be bright and provided with a central mark and a boundary line, in vertical relation to the vehicle longitudinal axis. For using the adjusting dimensions according to the adjusting table, the distance between the test surface and the headlamps to be adjusted should be 10 m.

Test surface  
(dimensions in cm)

- 1 Test surface
- 2 Parting line
- 3 Central mark
- 4 Break
- min. = minimum

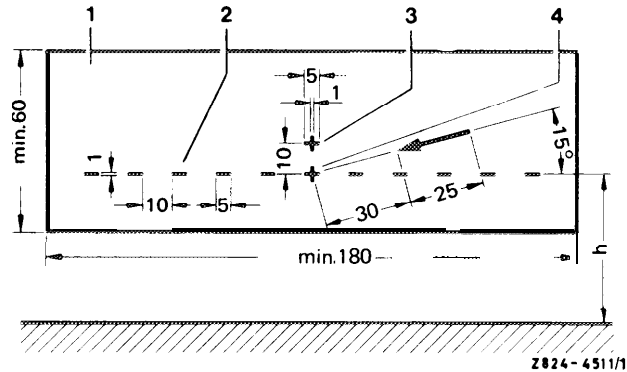

At an increased inclination of the light beam, e.g. on fog lamps, the distance should be 5 m; the specified adjusting dimensions are then cut to half. The central mark of the test surface should be located in the plane parallel to the vehicle longitudinal axis passing through the center of the headlamp to be adjusted. For each headlamp to be adjusted, the boundary line must be adjusted parallel to vehicle base and at height "h" above it.

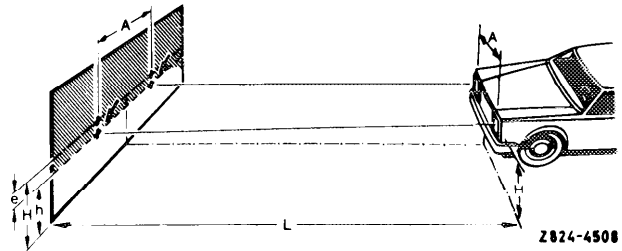

To make sure that enough vacuum is available for beam range regulation, run engine for a short moment prior to adjusting headlamps, and establish a vacuum by accelerating several times for a few short moments. Then move regulating switch from "0" to "3" and check whether headlamps are adjusting. If headlamps are not adjusting, repair fault.

**Check headlamp adjustment** in basic position "0" of regulatina switch and correct, if required.

#### Vehicles with level control

---

On vehicles with level control on rear axle, run engine at medium speed for approx. 30 seconds after mounting load and then permit vehicle to roll to a stop.

## B. Main headlamps

The main headlamps are adjusted according to the asymmetric low beam. The light-dark boundary should touch the parting line to the left of center. The intersection between the lefthand (as much as possible horizontal) and the righthand rising portion of the light-dark boundary should be on the vertical line through the central mark. For easier determination of the point of intersection, the lefthand half may be alternately covered and uncovered several times.

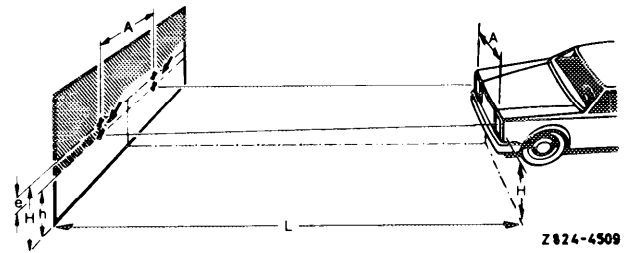

The center of the high beam should be on the central mark. For headlamps on which the high beam and the low beam (dimmer) are adjusted together, deviations of 20 cm each of the right or left or of 15 cm up to 10 cm down are permitted.

H = Height of headlamp center above base in cm

h = Height of parting line of test surface above base in cm

e = Adjusting dimension in cm (refer to adjusting table)

$$e = H - h$$

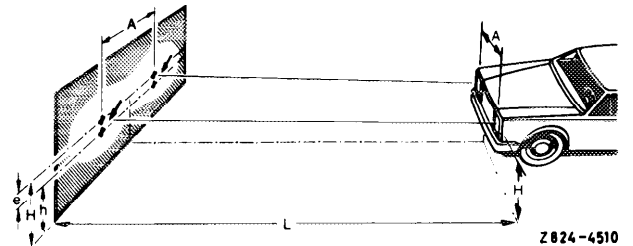

## C. Fog lamps

On fog lamps the highest point of the light-dark boundary should touch the parting line and should run as horizontally as possible across the minimum width of the test surface. In lateral direction the fog lamps are adjusted in such a manner that the light distribution is as much as possible asymmetrical to the vertical line through the central mark.

H = Height of headlamp center above base in cm

h = Height of parting line of test surface above base in cm

e = Adjusting dimension in cm (refer to adjusting table)

$$e = H - h$$

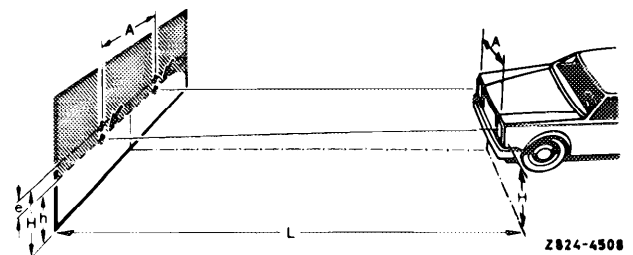

B. 

Removal

---

1 Unscrew cover (1) and remove in direction of arrow.

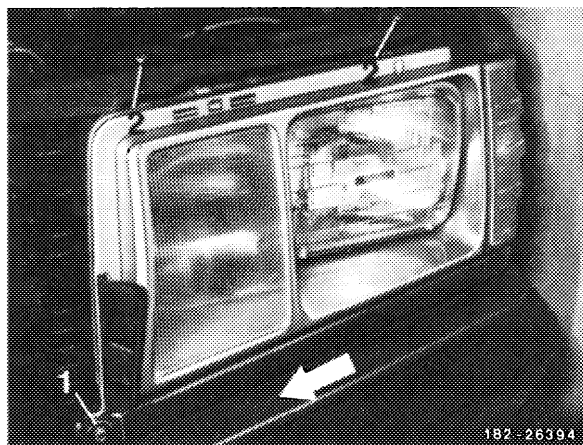

2 Unscrew knurled nut (arrow) of turnsignal lamp and slide turnsignal lamp out in forward direction.

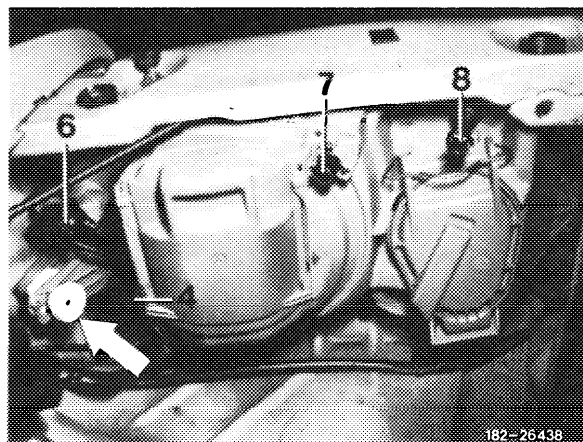

3 Unscrew upper fastening (2).

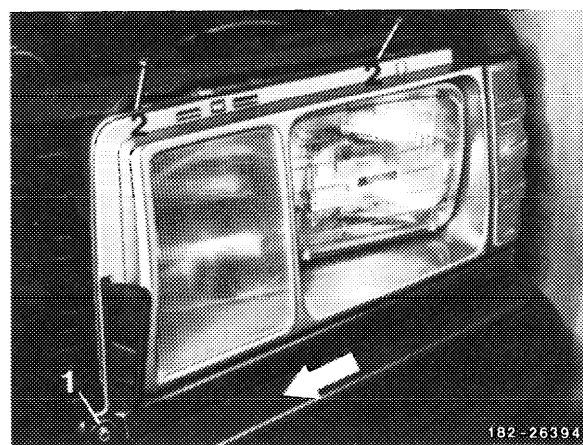

4 Unscrew lower fastening (3), remove lamp unit and pull off electrical connection.

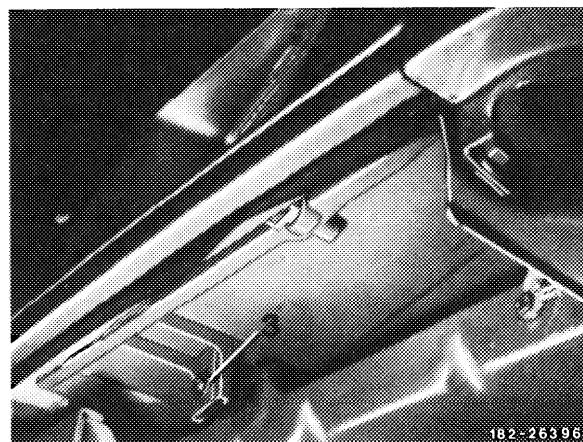

## Installation

5 Plug-on electrical connection (4).

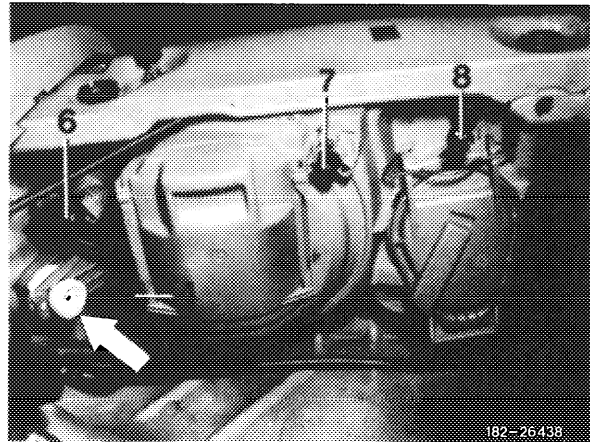

6 Introduce lower fastening into recess (arrow) and slightly tighten screw (3).

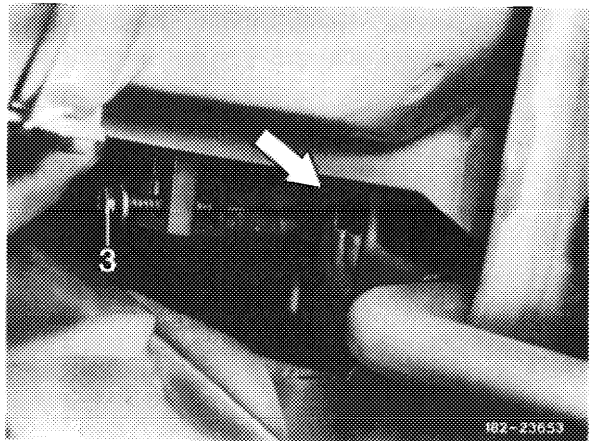

7 Position both upper screws (2) and tighten so that the lamp unit can still be moved.

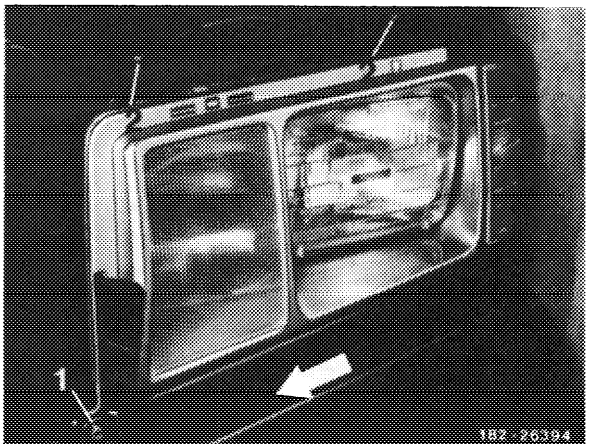

8 Install turnsignal lamp, making sure that the two lugs are slipped into guide (arrows).

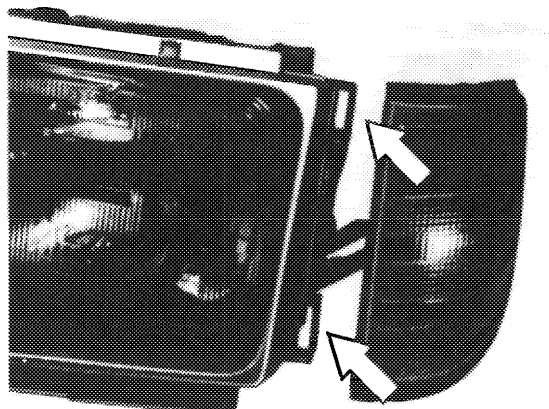

9 Close engine hood and adapt lamp unit in relation to engine hood and fender. Corrections in upward or downward direction can be made by means of plastic nuts (2a).

Tighten fastening screws at top and below.

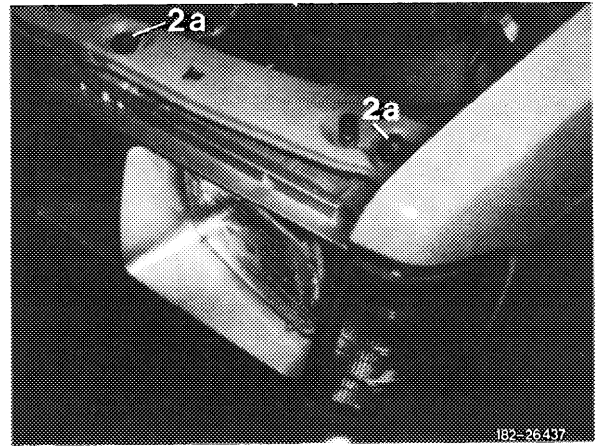

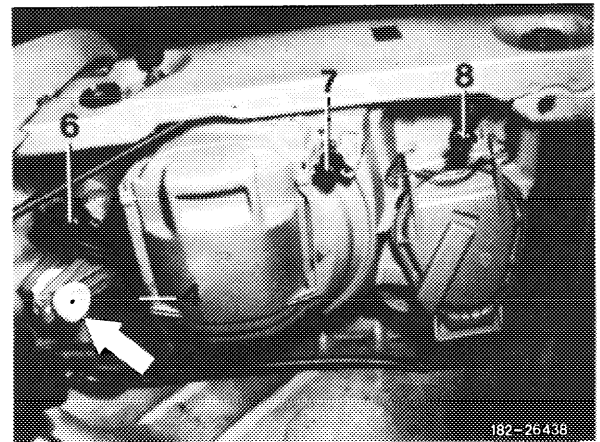

10 Check adjustment of headlamps and adjust, if required.

- 6 Adjusting screw for headlamp, left and right
- 7 Adjusting screw for headlamp, high and low
- 8 Adjusting screw for fog lamp, high and low

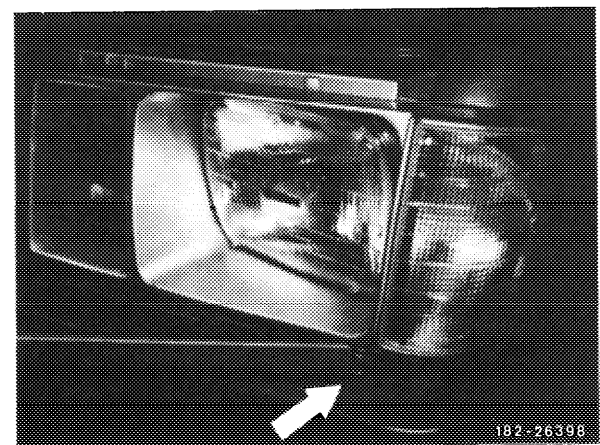

11 Engage cover on outside (arrows) and screw down.



B.  (sealed beam unit)

**Removal**

---

**Main headlamp with bulb**

1 Remove cover (6) in upward direction.

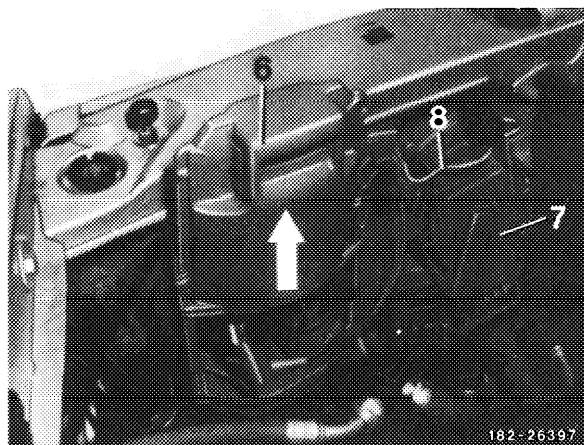

2 Pull off electrical connection.

3 Force off clip (3a) in direction of arrow.

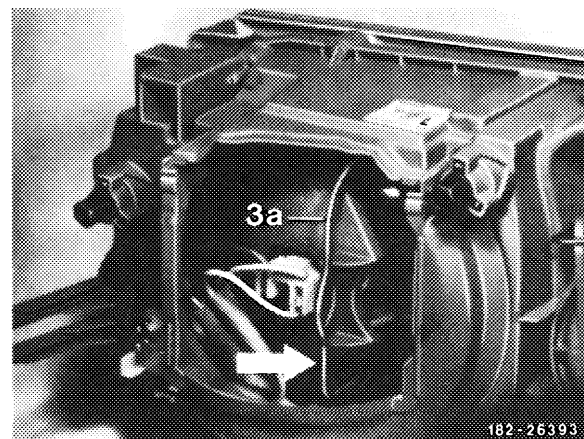

4 Remove sealed beam unit (2) in forward direction.

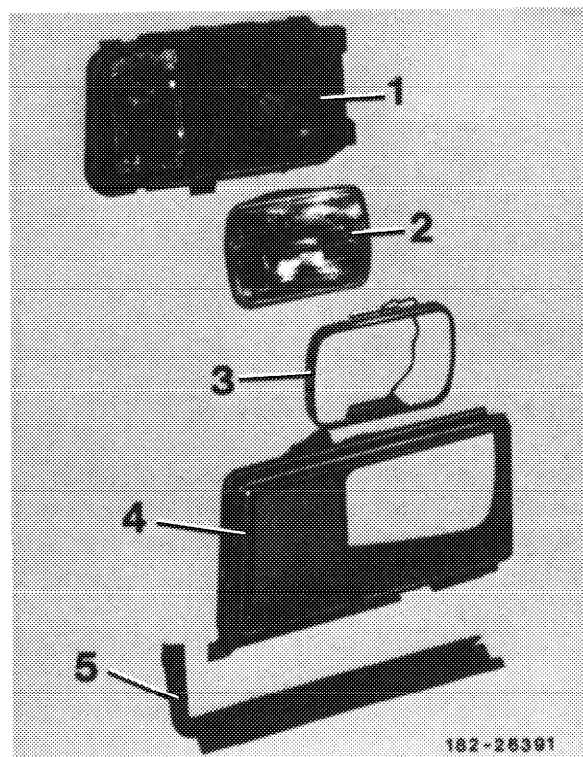

- 1 Housing
- 2 Sealed beam unit
- 3 Holding frame
- 4 Covering frame with lens
- 5 Rubber seal

### Bulb for fog lamp

5 Push off clip (8) in upward direction and remove cover (7).

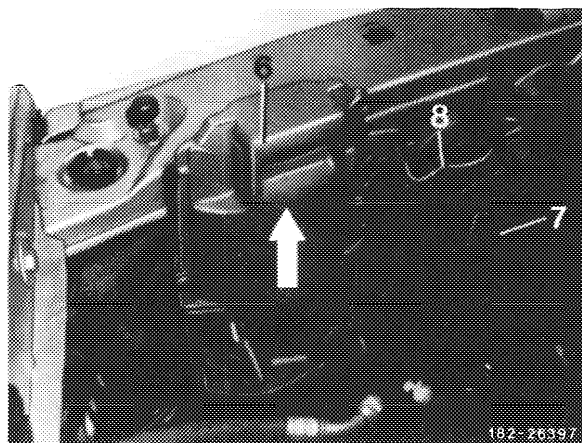

6 Pull off electrical connection (9), unclip fastening clamps (10) and remove H3-bulb.

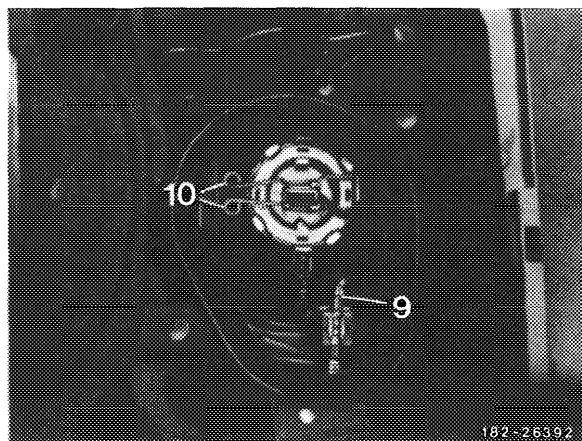

### Bulb for turnsignal and side marker lamp

7 Pull off electrical connection.

8 Loosen socket by turning to the left and remove. Unscrew bulb (12 V 2 1/5 W) from bayonet seat of socket.

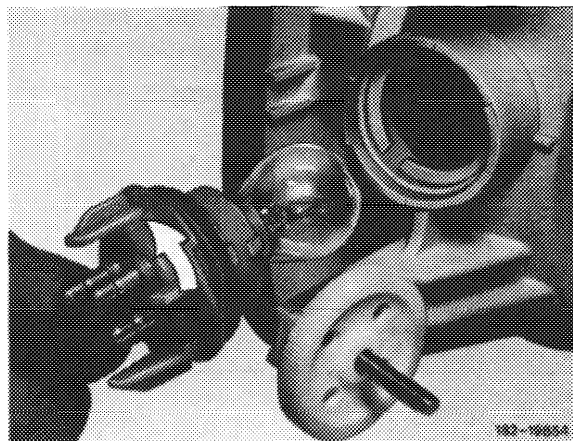

### Installation

---

9 For installation proceed vice versa.

**Note:** During installation, pay attention to correct seat of bulb. Do not touch bulb with bare fingers on glass body, but use a soft rag free of grease.



### Removal

---

- 1 Remove lamp unit (82-052).
- 2 Unclip the 4 holding clamps (arrows), 2 on top and 2 below on housing, and remove covering frame with lens.

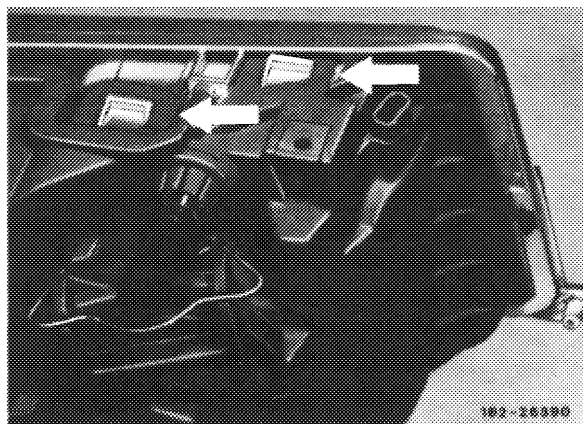

Holding clamps, top

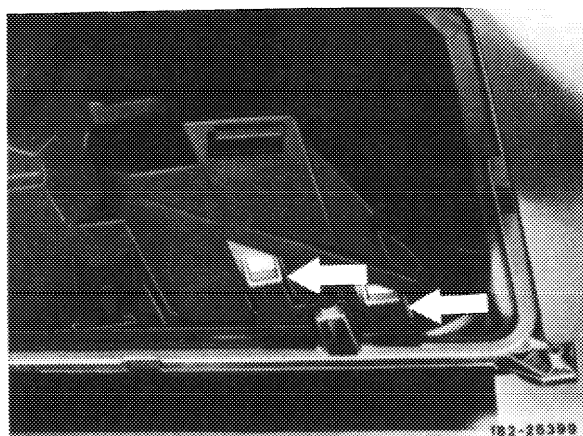

Holding clamps, below

### Installation

---

- 3 Place covering frame on housing and push on uniformly until holding clamps at top and bottom are audibly engaging.

**Removal**

---

- 1 Unlock lamp carrier (arrows) and remove.
- 2 Pull off electrical connection (6).

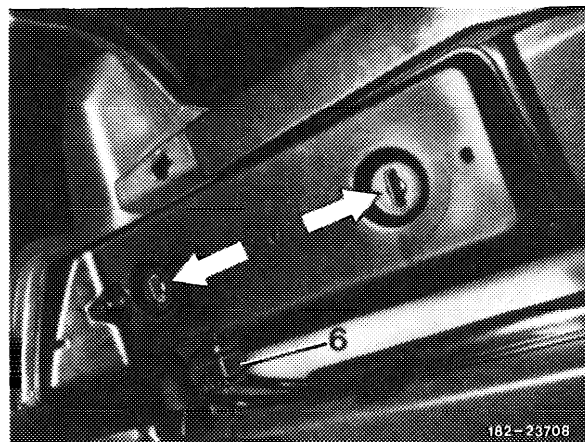

- 3 Unscrew 6 fastening nuts (2).
- 4 Unclip detent (3) and remove reflector (1).

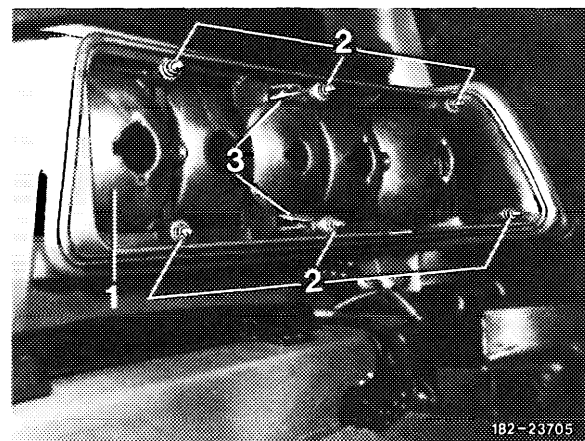

- 5 Remove light window (arrow) in outward direction.

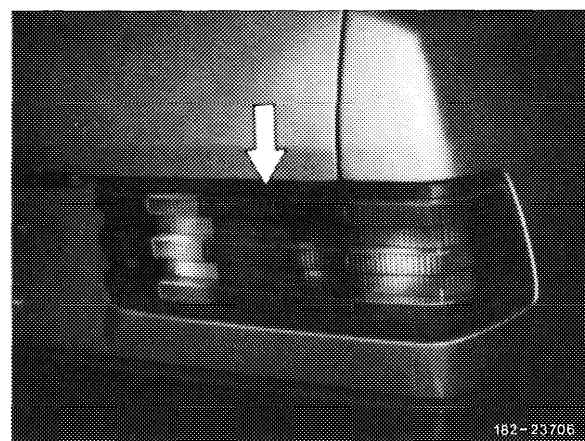

## Installation

6 Insert light window with rubber seal from outside into body.

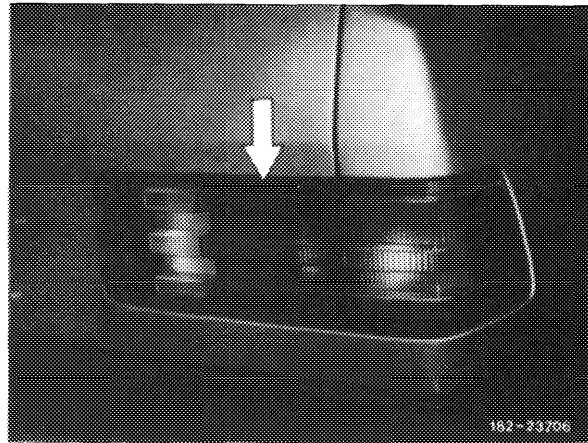

7 Mount reflector (1) and engage.

8 Uniformly screw down 6 fastening nuts (2).

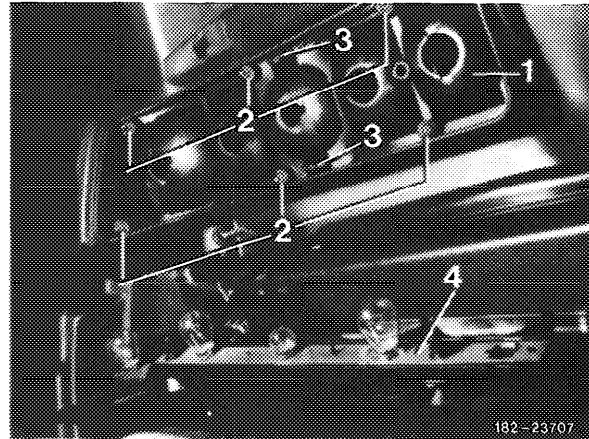

9 Mount lamp carrier and lock.

10 Plug-on electrical connection (6).

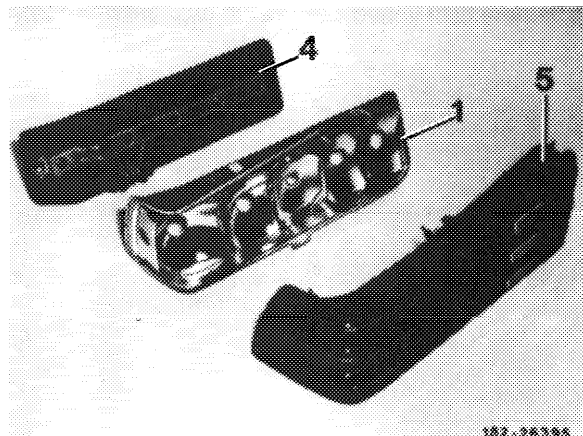
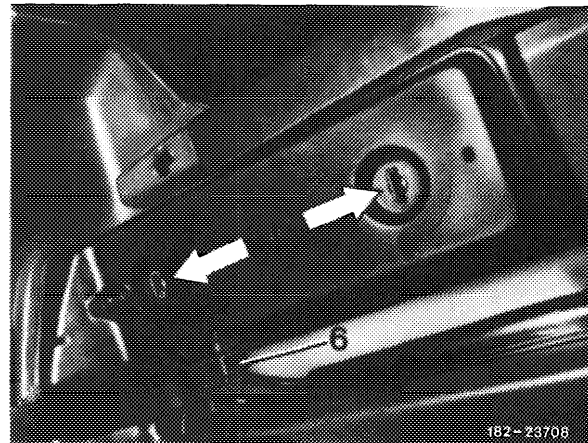

Tail lamp unit (USA)

1 Reflector  
4 Lamp carrier  
5 Light window

During removal and installation pay attention to the following items:

- 1 The licence plate lamp is fastened by means of 2 screws.
- 2 Upon removal of licence plate lamp, the bulb can be removed from socket.

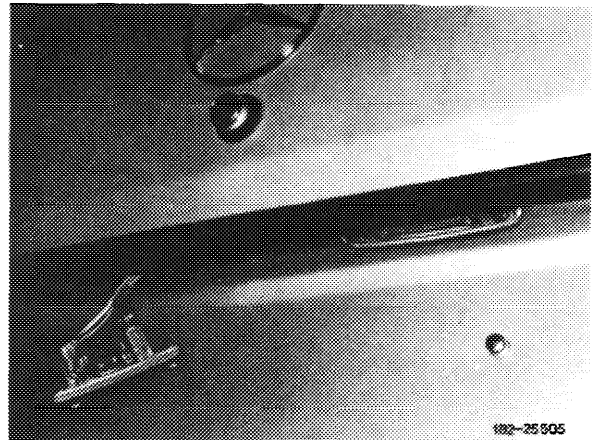

- 3 When instelling licence plate lamp, pay attention to correct seat of seal.

82-395 Electric wiring diagram, heatable rear window

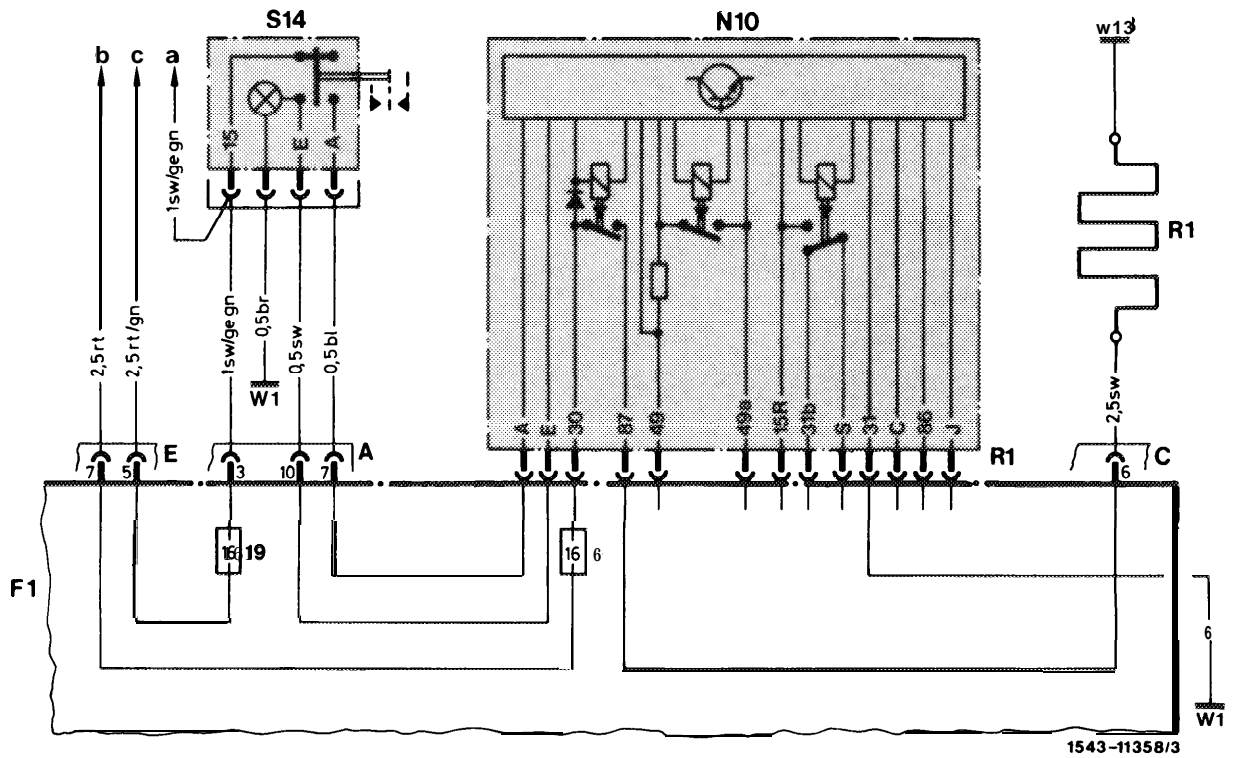

- |     |  |   |   |
|-----|--|---|---|
| F1  | Central electrical system  | A | 10-pole coupling harness interior               |
| N10 | Combination relay (turn signal, heatable rear window, wiper motor) | C | 16-pole coupling harness tail lamp unit         |
| R1  | Heatable rear window   | E | 8-pole coupling harness ignition starter switch |
| S14 | Switch heatable rear window  | a | To cigar lighter with ashtray light R3          |
| W1  | Main ground (behind instrument cluster)                            | b | To ignition starter switch S 2/1 terminal 30    |
| w13 | Ground, heatable rear window                                       | c | To ignition starter switch S 2/1 terminal 15    |

## 82-505 Removal and installation of radio

During removal and installation pay attention to the following items:

- 1 The radio is fastened by means of holder of ash-tray.

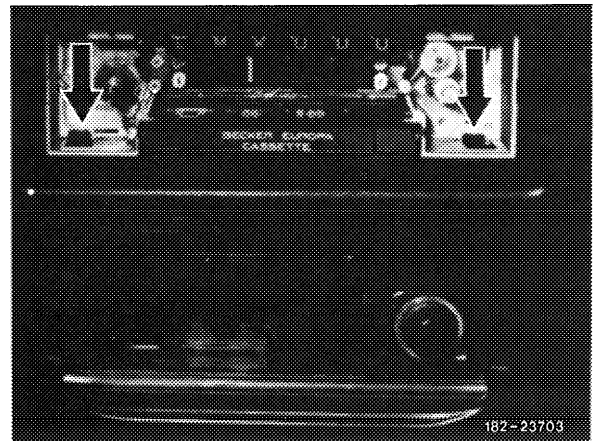

- 2 The holder is screwed to console by means of two screws.

Removal of knobs or molding of radio is not required, the radio can be completely pulled out of console.

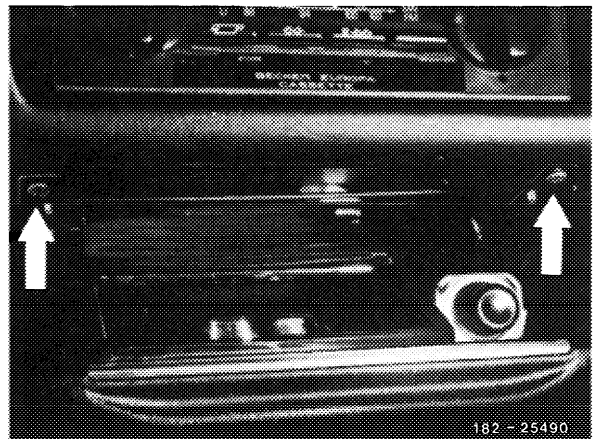

- 3 The radio is electrically connected on cigar lighter.

Note: Antenna line as well as the control line for automatic antenna are not available as standard equipment.

- 1 Cigar lighter
- 2 Lamps
- 3 Intermediate coupling radio harness
- 4 Terminal 15 R (positive)
- 5 Terminal 31 (negative)

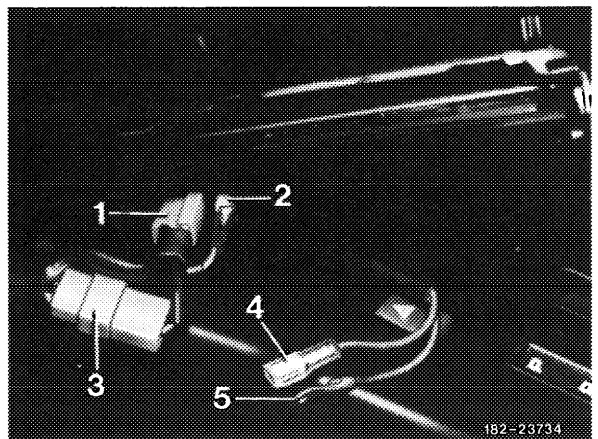

## 82-512 Removal and installation of speaker, front and rear

---

During removal and installation pay attention to the following items:

### Speaker, front

---

- 1 The speaker cover is engaged at the front in instrument panel and fastened at the rear by means of 2 screws.
- 2 The speaker can be pushed out of instrument panel by means of a plastic wedge.

3 Recess for cover

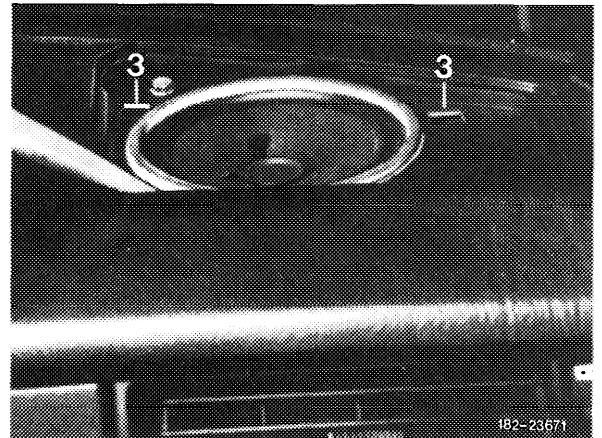

- 3 Speaker is held in instrument panel by means of 2 spring clamps (1).

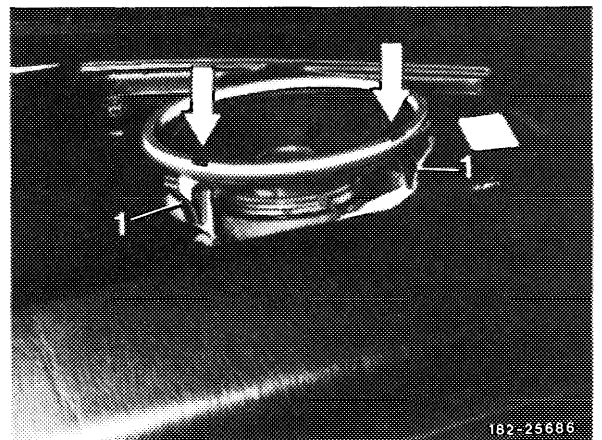

- 4 When installing speaker, insert into instrument panel first with support in forward position and push in until the spring clamps are engaging.

The two color marks (arrows) should point to the rear.

## Speakers, rear

---

5 The rear speakers are screwed to hat rack together with speaker cover. They can be removed or installed complete with hat rack.

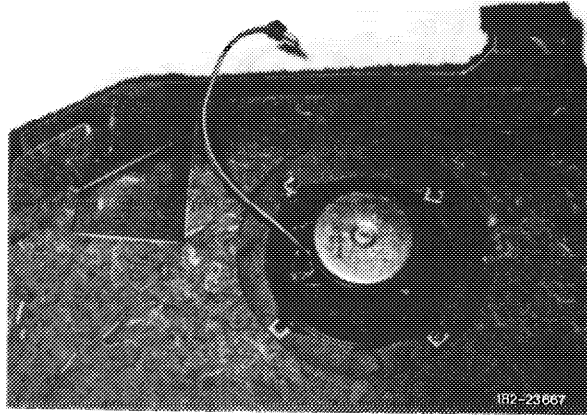

6 By means of an 1/4" ratchet and a pertinent element, separate removal (without hat rack) is also possible.

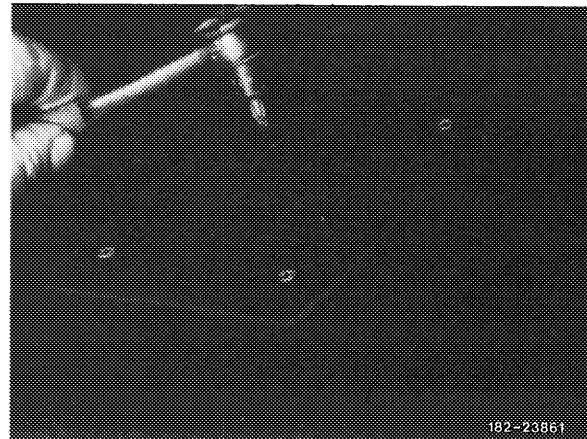

7 The sound guiding hose together with the bore toward trunk will improve quality of sound.

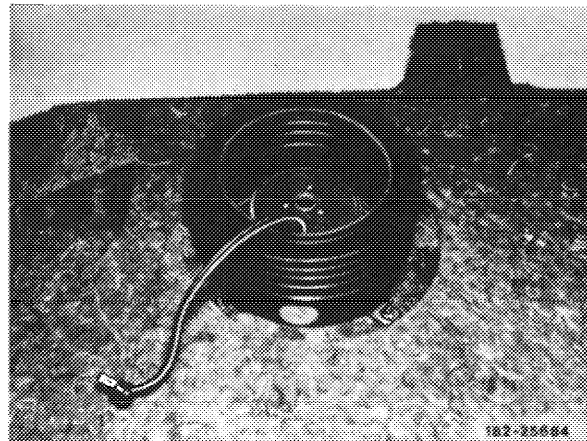



The antenna can be moved into three different positions by means of the antenna switch with the radio switched on.

**Antenna switch in center position**

The antenna extends automatically approx. 30 cm when the radio is switched on. Actuation of switch for a short moment extends antenna into position most favorable for reception.

**Antenna switch engaged in extension position**

Antenna extends to its full length.

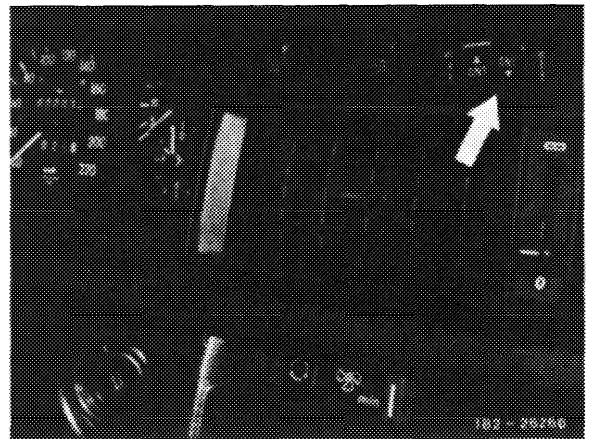

**Antenna switch engaged in retracting position**

Antenna is not extending, e.g. when playing cassettes or antenna retracts completely following previous extension.

If the ignition or the radio is switched off, the antenna retracts completely.

Wiring diagram automatic antenna (USA)

- F1 Central electrical system
- M11 Automatic antenna
- S61 Switch automatic antenna
- W6 Ground, trunk wheelhouse left
- C 16-pole coupling tail lamp unit harness
- E 8-pole coupling harness to ignition starter switch S2/1
- a To ignition starter switch S2/1 terminal 30
- b To trunk lamp E18
- d Control line to radio A2

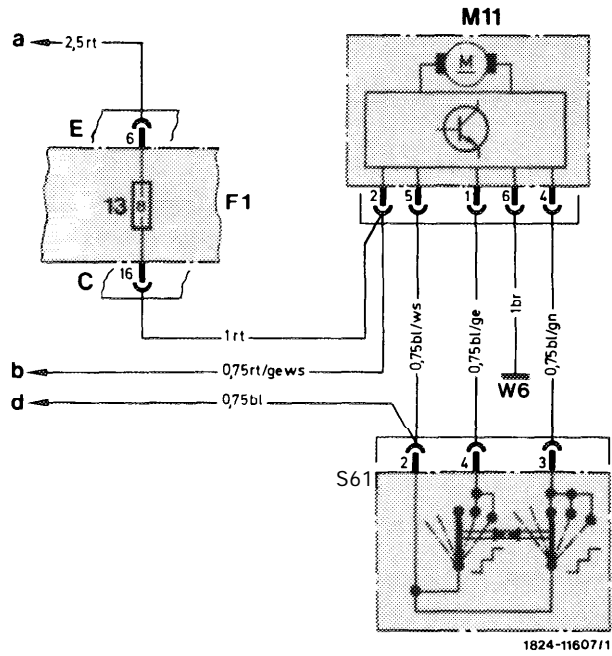

1824-1160711

During removal and installation pay attention to the following items:

The antenna head is held in fender by means of a rubber grommet.

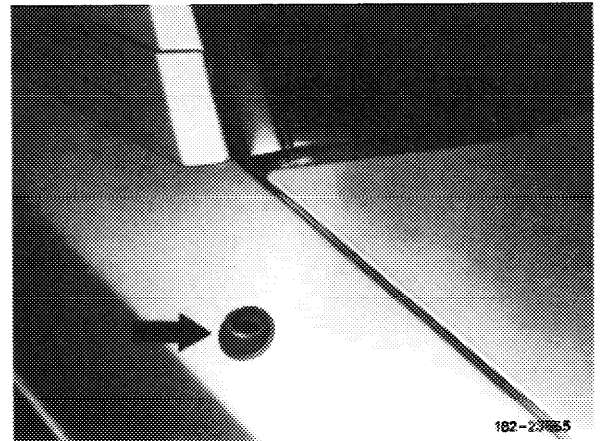

2 The required ground connection is made by means of a grounding strap.

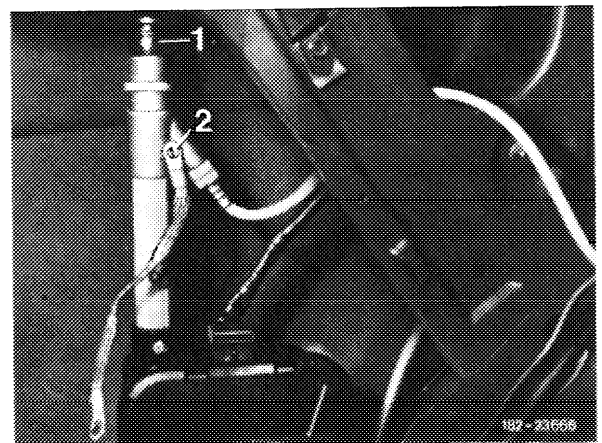

- 1 Antenna head
- 2 Grounding strap

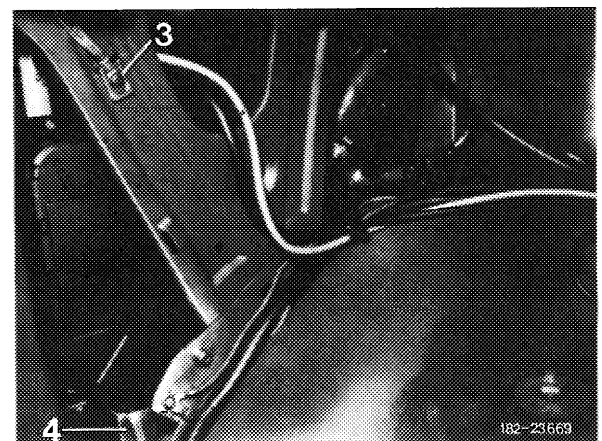

- 3 Grounding strap connection
- 4 Fastening holder

3 Dimensions for drilling antenna bore in fender rear left.

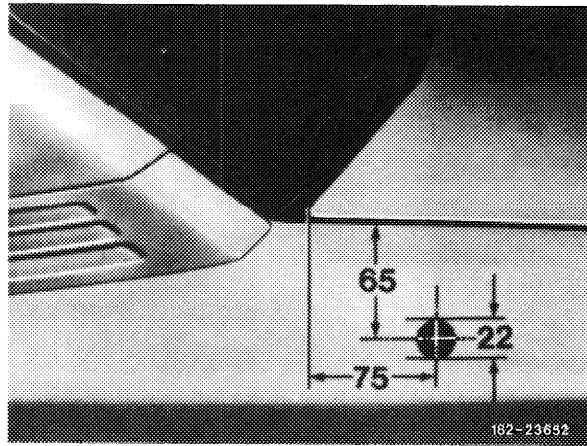

## 82-610 Removal and installation of profilated rubber of wiper blade

---

### Removal

---

1 Remove wiper blade.

2 Push back both holding springs from direction of closed profilated rubber side and pull completely out of rubber.

3 Disconnect profilated rubber on holding clamps of wiper blade.

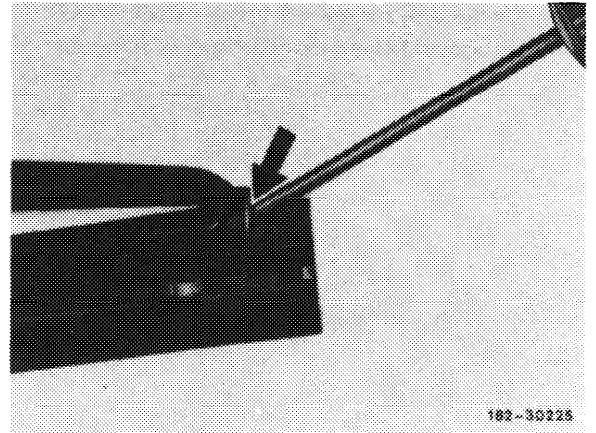

### Installation

---

4 Engage profilated rubber on holding clamps of wiper blade.

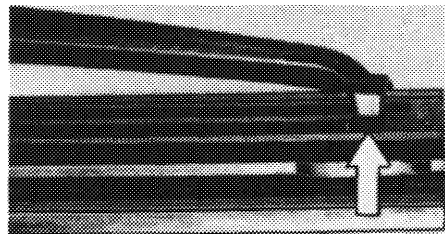

5 Slip holding springs from side of open profile into rubber in such a manner that the crown points toward windshield.

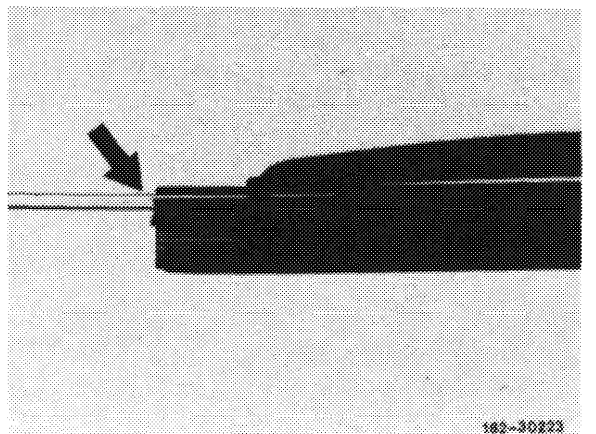

6 Place wiper blade with holding springs on a firm base and push holding springs one after the other into the profiled rubber.

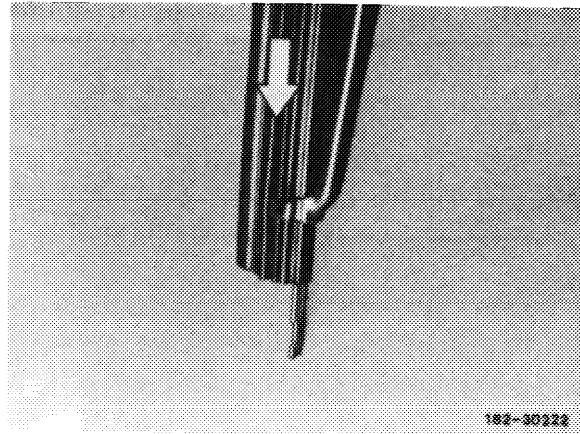

Note: The holding springs will engage easier, if the front end is chamfered and wiped with soap water.

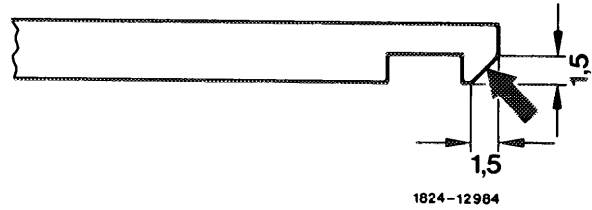

## 82-680 Removal and installation of wiper motor

---

### Note

---

When working on wiper system, pull off ignition key. Movements on wiper arm or wiper linkage may lead to activation of automatic parking position system starting at ignition key position "1". Undesired movement of wiper may lead to hand injuries.

1 st version

### Removal

---

- 1 Remove cover on air intake.
- 2 Unscrew wiper system.
- 3 Remove cover of central electrics and unscrew screws.
- 4 Pull central electrics slightly forward, lift and pull out socket for wiper system in front half in downward direction.
- 5 Remove wiper system.
- 6 Unscrew nut on wiper motor shaft and push off crank arm with linkage.

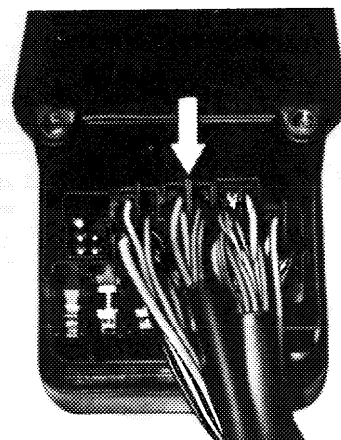
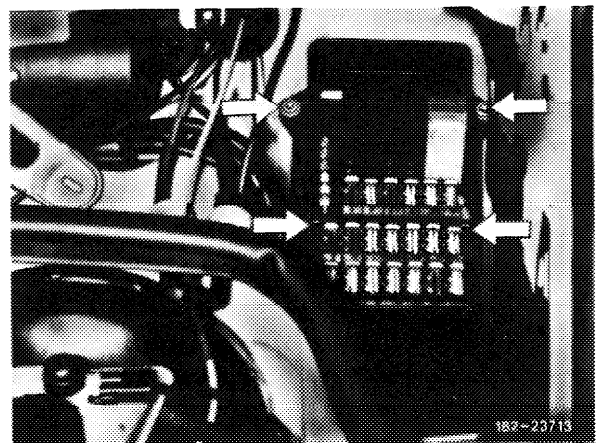
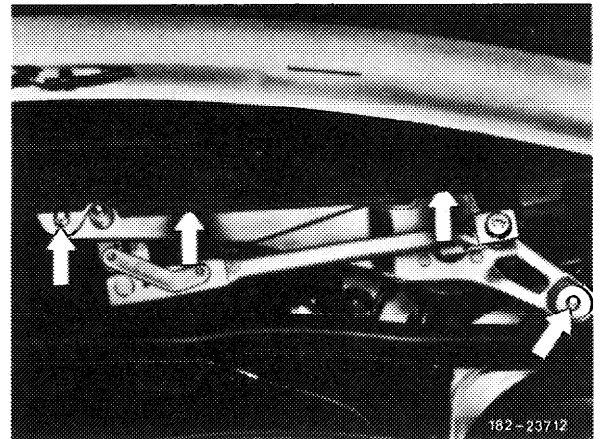

7 Unscrew wiper motor.

### Installation

---

8 Screw wiper motor to base plate.

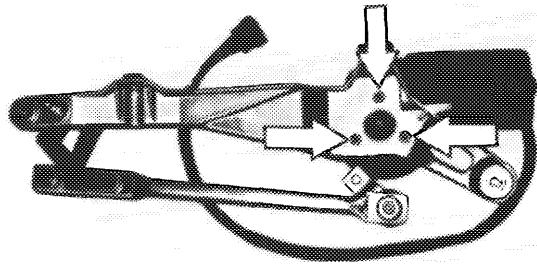

182-23714

9 Push crank arm on wiper motor shaft, making sure that crank arm and push rod are in parallel with each other.

10 Screw crank arm to wiper motor.

11 Install wiper system.

12 For further installation proceed vice versa.

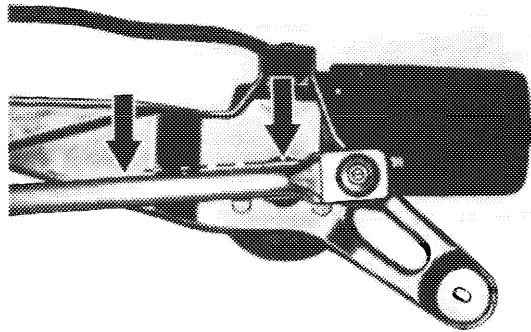

182-23715

### 2nd version (panorama windshield wiper)

#### Removal

---

1 Remove cover on air inlet (Group 83).

2 Open cover plate, unscrew screw and remove.

3 Pull off wiper arm.

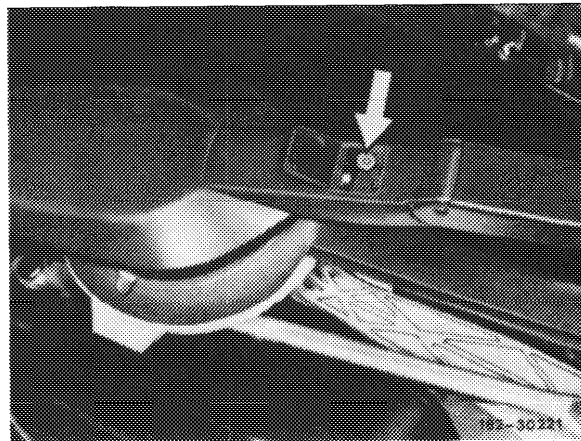

182-50221

4 Unscrew nuts (5 each).

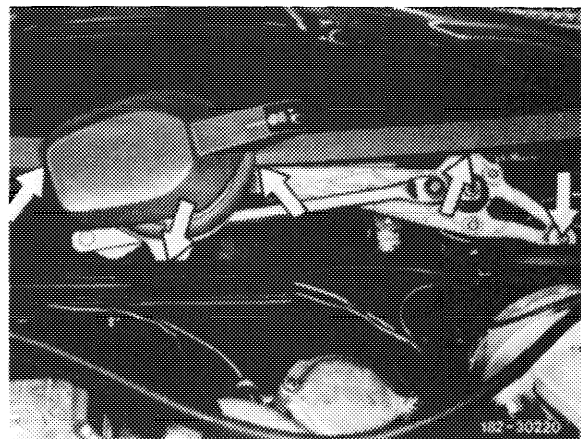

182-50220



5 Pull off bearing bracket and remove wiper stop, while separating electric plug coupling.

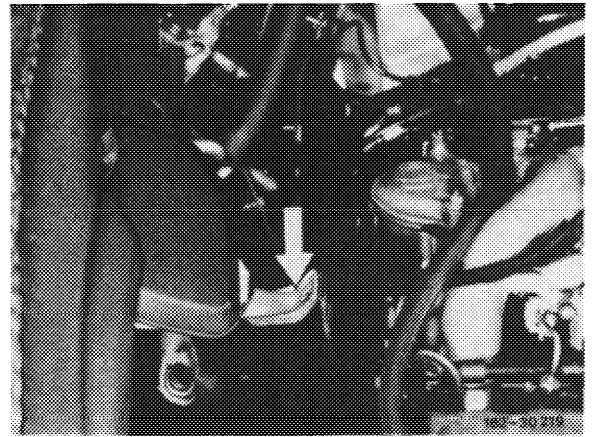

6 Unscrew nut on wiper motor shaft and force off crank arm.

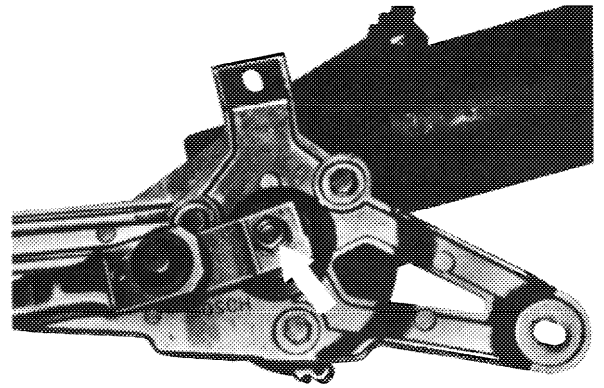

162 -30226

7 Unscrew wiper motor and remove.

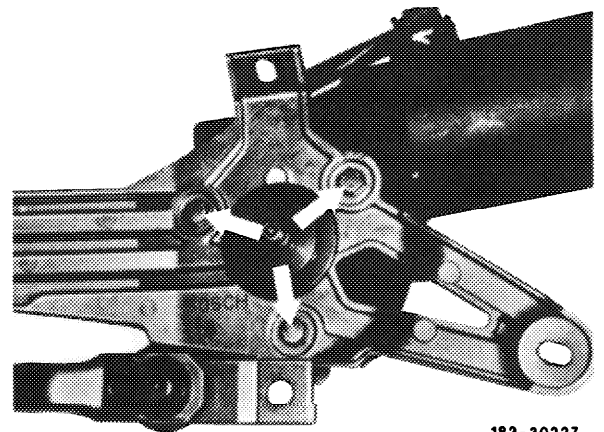

162 -30227

### Installation

---

8 Screw on wiper motor (5 Nm).

**Note:** Wiper motor should be in parking position. Connect to cable assembly, if required and let run into parking position.

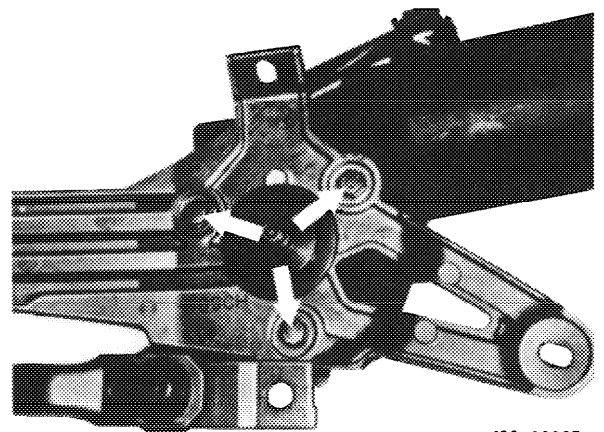

162 -30227

9 Plug crank arm on wiper motor shaft and align.

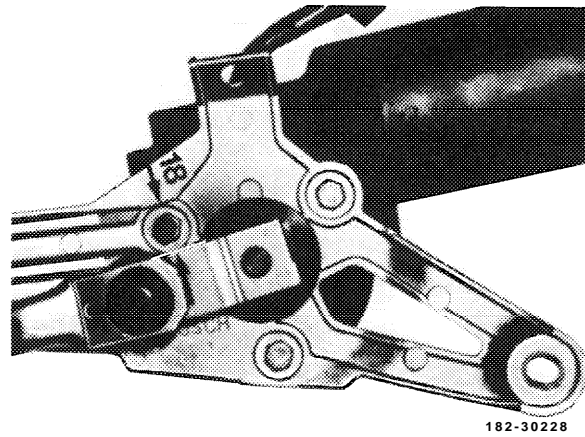

10 Screw on nut and tighten to 19 Nm.

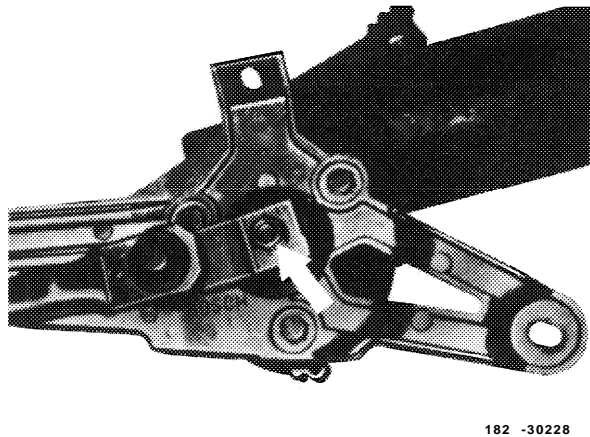

11 Insert wiper unit, making sure that the sealing rubber rests on window pane.

12 Continue installation in vice-versa sequence.

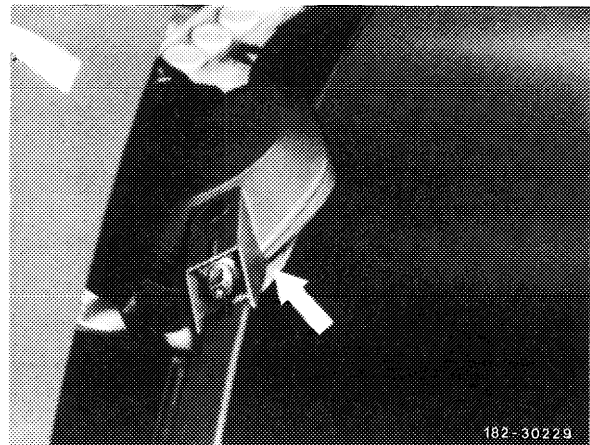

## 82-760 Removal and installation of wiper linkage

---

1 st version

### Removal

---

- 1 Remove wiper unit (82-680).
- 2 Unscrew nut on wiper motor shaft and force off crank arm.

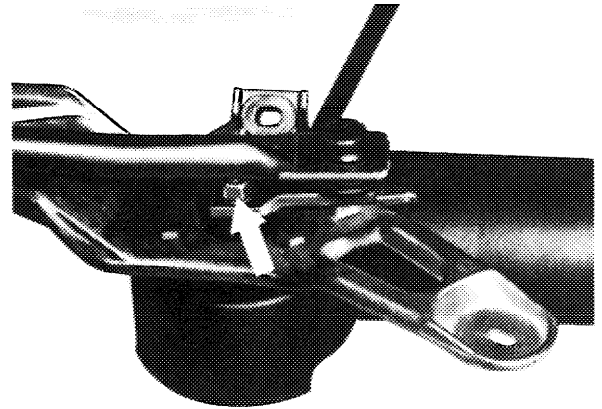

- 3 Force off locking ring on wiper shaft and pull wiper arm out of bearing.
- 4 Remove wiper linkage.

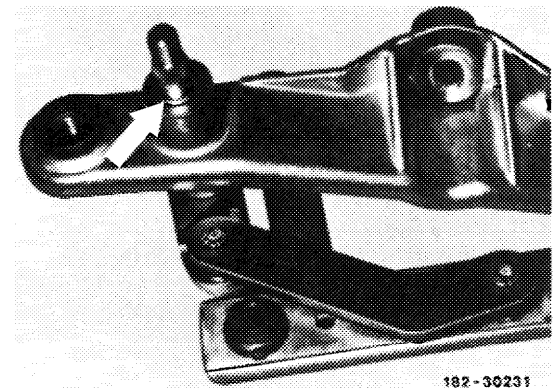

### Installation

---

- 5 Slide wiper shaft into bearing and force on locking ring.

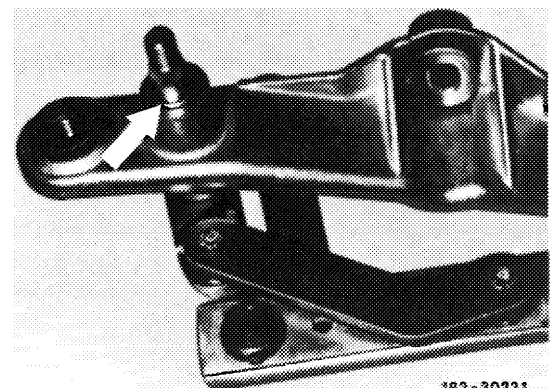

6 Press crank arm on wiper motor shaft, making sure that the crank arm and the pushrod are in parallel with each other.

Note: Wiper motor should be in parking position. Connect to cable assembly, if required, and let run into parking position,

7 Tighten crank arm (19 Nm).

8 Install wiper system.

9 For further installation proceed vice versa.

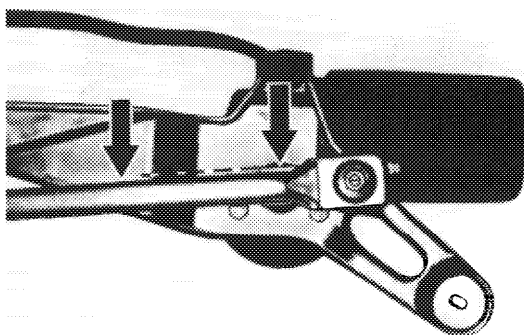

182-23715

## 2nd version (panorama windshield wiper)

### Removal

---

1 Remove wiper system (82-680).

2 Turn nut of wiper motor shaft and force off crank arm.

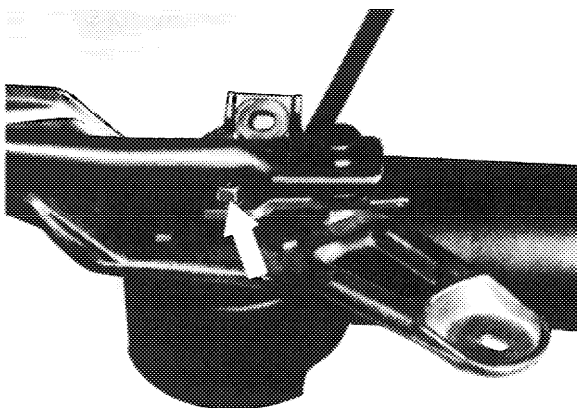

182-30230

3 Turn nut of wiper shaft and force off linkage.

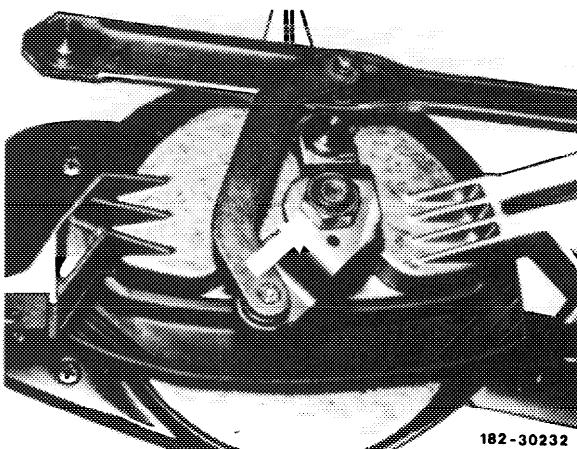

182-30232

### Installation

---

4 Plug crank arm on wiper motor shaft and align.

Note: Wiper motor should be in parking position. If required, connect to cable harness and run into parking position.

5 Tighten nut to 19 Nm.

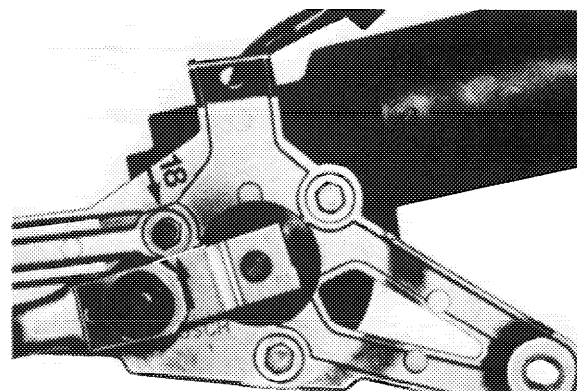

182-30228

6 Align gear head in such a manner that the markings are in alignment (parking position),

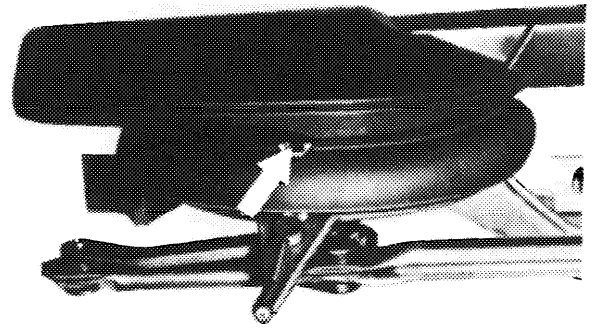

182-30233

7 Plug linkage on wiper shaft and tighten to 29 Nm.

8 For further installation proceed vice versa.

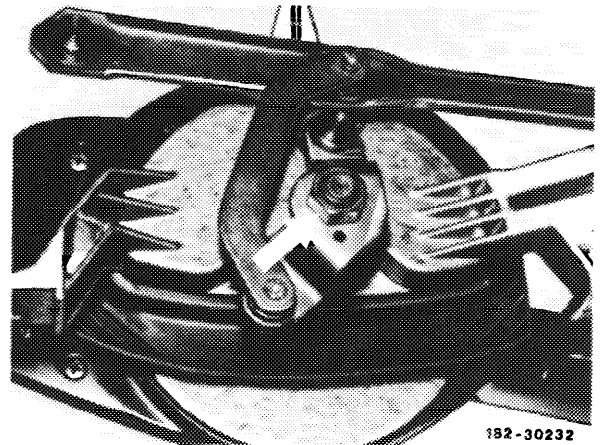

182-30232

## 82-765 Removal and installation of rubber seal under wiper gears

---

### Removal

---

- 1 Remove wiper system (82-680).
- 2 Turn nut of wiper shaft and force off linkage.

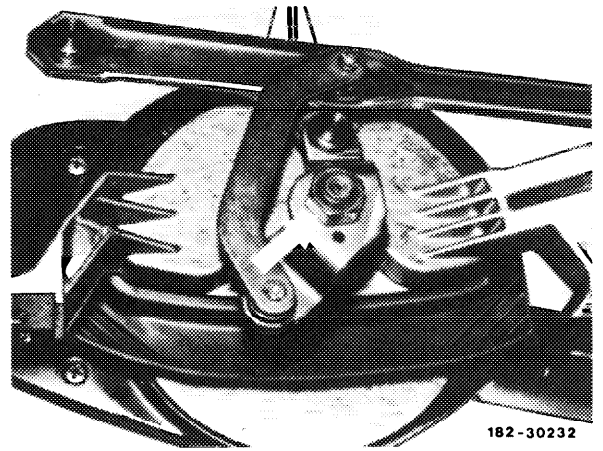

- 3 Force off locking ring.
- 4 Turn gear head into center position (angular in relation to plate) and pull out of bearing.

Note: Do not knock out with hammer. Gear head can be pulled out in center position only.

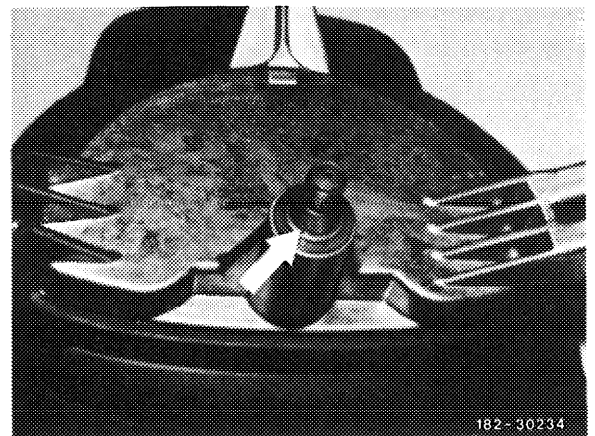

- 5 Remove rubber seal.

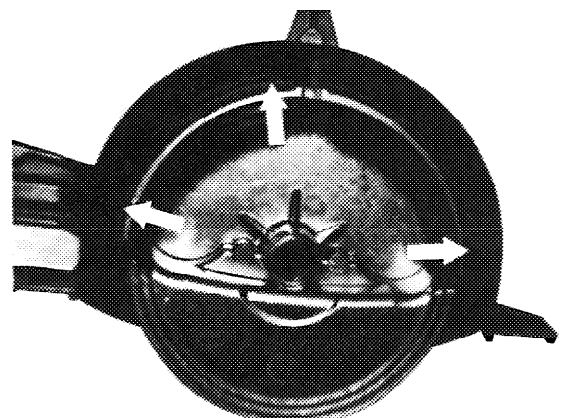

## Installation

---

6 Coat rubber seal with MB universal glue and place on housing.

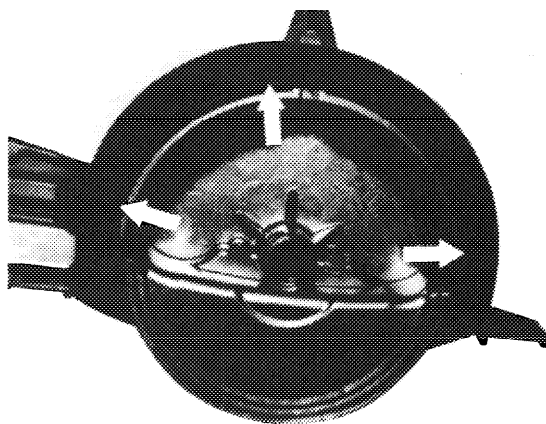

182-30235

7 Introduce gear head in center position into bearing.

**Note:** Pushrod must be completely run in. Make corrections by turning gearwheel, if required.

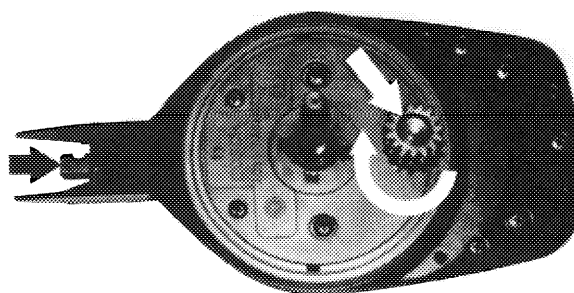

182-30236

8 Align gear head in such a manner that the markings are in alignment (parking position).

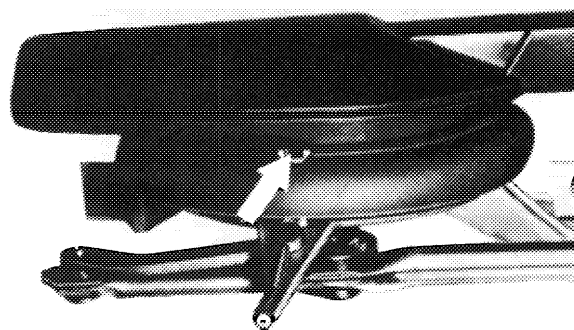

182-30233

9 Plug linkage on wiper shaft and tighten to 29 Nm.

10 For further installation proceed vice versa.

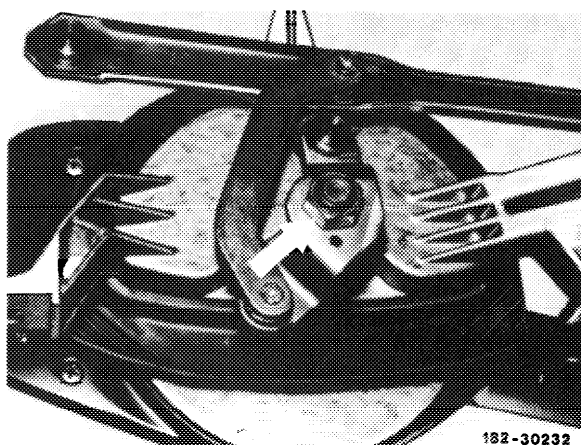

182-30232





**Electrically heated nozzle**

**1 st version**

A PTC heater resistor is installed in three-jet nozzle. This PTC heater resistor increases its resistance with increasing heat.

After switching on ignition, a current of approx. 300 mA flows via PTC heater resistor and reduces with increasing heat to a settled current of 100 mA.

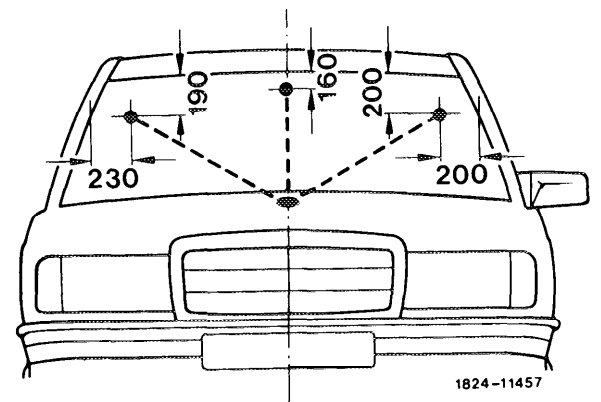
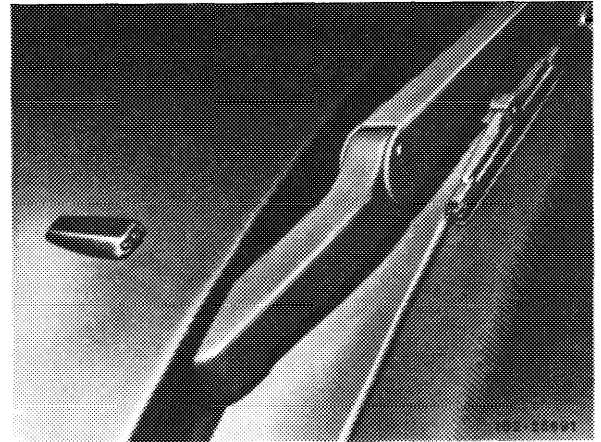

**2nd version**

Two double-jet nozzles are installed on version with lifting cam wiper. Operation, as well as removal and installation are similar in principle as on 1st version.

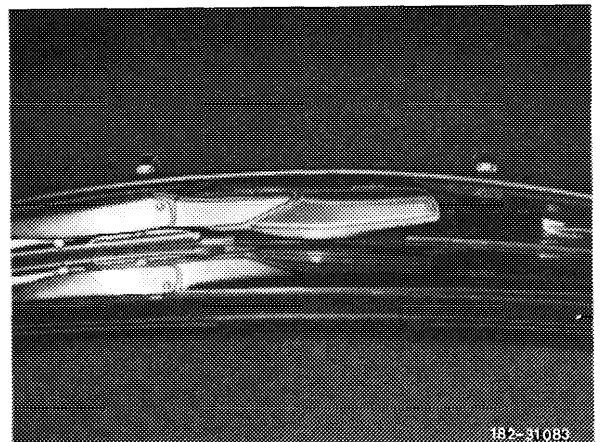

### Nozzle adjustment 2nd version

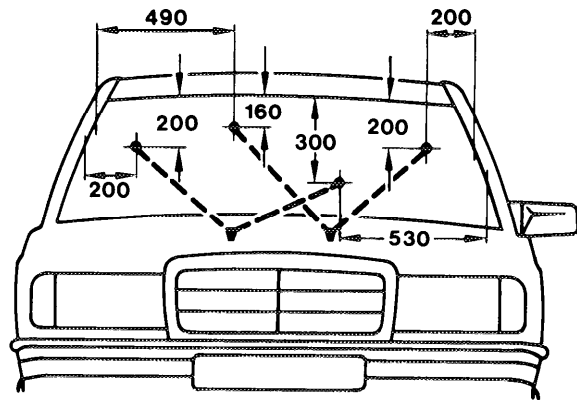

1824 - 13 249

### Check valve

---

The check valve is located on front, righthand wheel house.

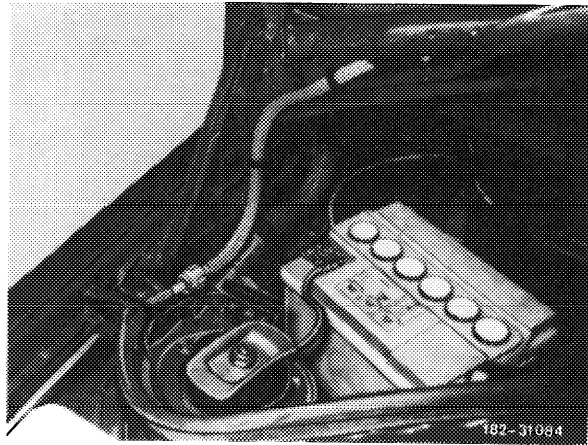

### Repair note

#### Removing and installing nozzle

---

- 1 Pull off electrical connection (1) and hose (2).
- 2 Push out nozzle in direction of arrow and remove in upward direction.
- 3 During installation, push in until nozzle engages.

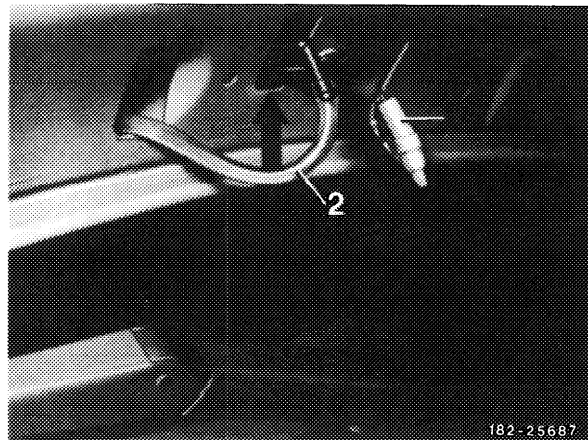

Actuation by means of a button which returns to its rest position after switching on.

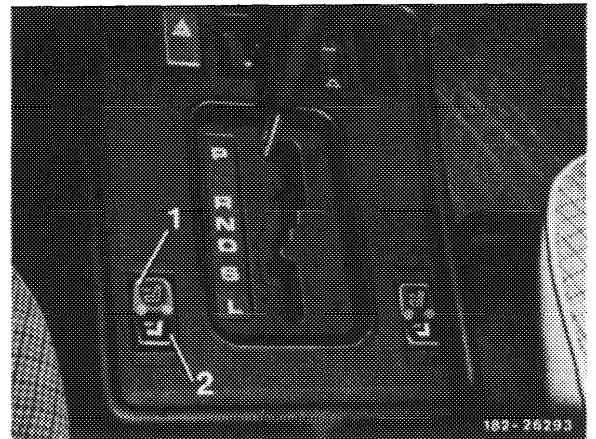

Stage 1 or 2 are engaged by pushing once on respective symbol, during which one indicator lamp will light up in stage 1 and two indicator lamps in stage 2.

The heating system will be switched off when the same signal is pushed again.

The On-period of the two heating stages is limited by an electronic relay. The relay is located behind cover in legroom under floor mat left or right.

After approx. 5 minutes follows an automatic switch-over from stage 2 (high heating capacity 60 W) to stage 1 (low heating capacity 15 W), and after approx. 30 minutes the seat heater will be switched off.

The automatic heating sequence is interrupted when the ignition starter switch (glow starter switch) is switched off.

When the ignition starter switch (glow starter switch) is switched on again, the seat heater switch must be newly actuated (similar to heatable rear window).

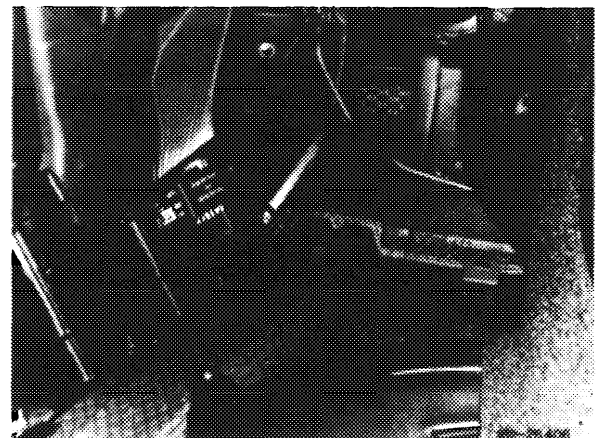

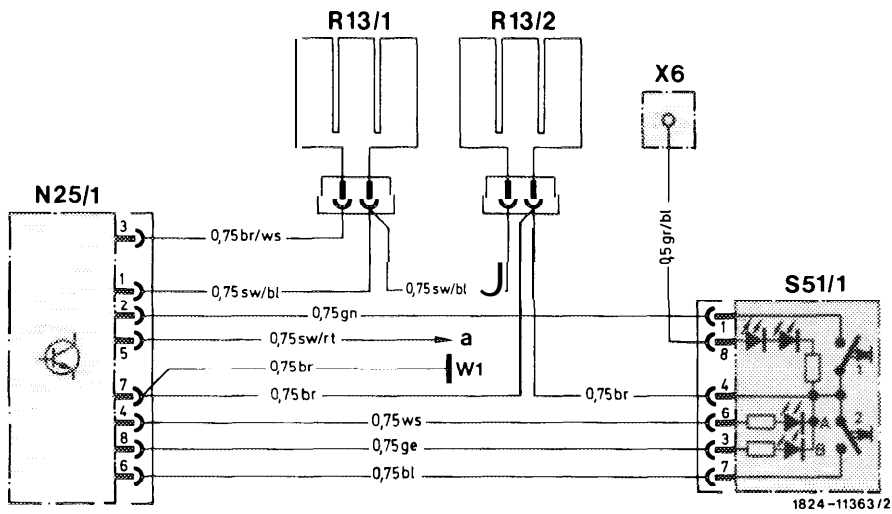

**Wiring diagram seat heater left**

- N25/1 Relay seat heater front left
- R13/1 Heating cushion seat, front left
- R13/2 Heating cushion backrest, front left
- S51/1 Switch seat heater left
- W1 Main ground (behind instrument cluster)
- X6 Line connector terminal 58 d
- a To line connector interior X5/1 terminal 15

## 82-833 Electrically adjustable outside rear view mirror

The righthand outside rear view mirror is electrically adjustable. Two motors in mirror are activated by a switch.

The mirror is vertically adjusted in upward or downward direction with motor M1. It is horizontally driven in inward or outward direction with motor M2.

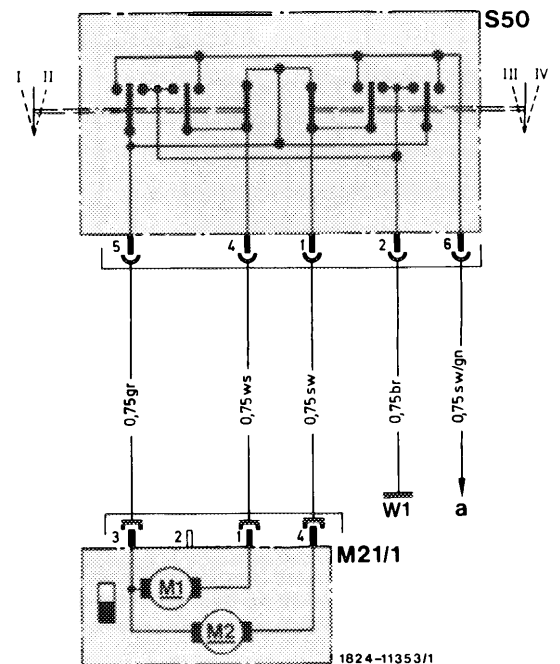
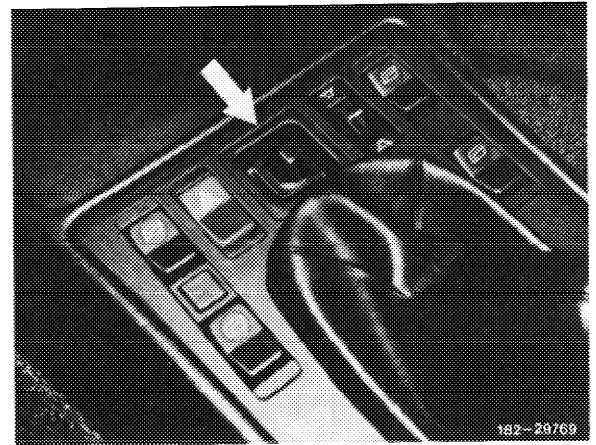

Wiring diagram electrically adjustable outside rear view mirror

M21/1 Outside mirror for front passenger, electrically adjustable

S50 Switch of electrically adjustable outside mirror  
 I Mirror adjustment vertically in upward direction  
 II Mirror adjustment vertically in downward direction

I II Mirror adjustment horizontally in inward direction  
 IV Mirror adjustment horizontally in outward direction

W1 Main ground (behind instrument cluster)  
 a To line connector interior X5/1 terminal 15

General

As special equipment there are mechanically and electrically adjustable outside rear view mirrors with electrical heater. The heater is on back of plate glass and firmly connected therewith. Also on back of mirror plate is a thermostat, which engages and disengages the heater depending on the prevailing temperature. The mirror glass can be separately replaced (88-900).

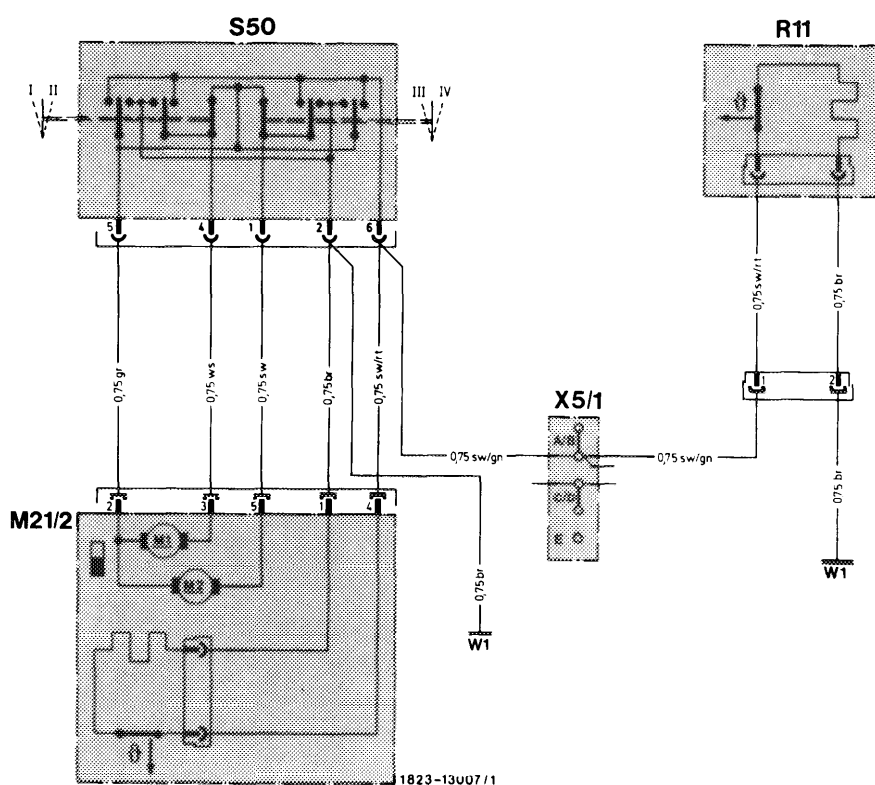

Wiring diagram outside rear view mirror with electrically heated plate glass

- M21/2 Outside mirror, for front passenger, electrically adjustable and heated
- R11 Outside mirror, for driver, electrically heated
- S50 Switch, electrically adjustable outside mirror
  - I Mirror adjustment vertically in upward direction
  - II Mirror adjustment vertically in downward direction
  - III Mirror adjustment horizontally in inward direction
  - IV Mirror adjustment horizontally in outward direction
- W1 Main ground (behind instrument cluster)
- x5/1 Line connector interior terminal 15

## Operation

---

The heater is operational in key position 2 (terminal 15).

The thermostat engages the heater at ambient temperatures below  $5 \pm 3^{\circ}\text{C}$ . The heater is operational up to an ambient temperature of  $15 \pm 3^{\circ}\text{C}$  and switches off when this temperature is attained.

If the temperature drops again below  $5 \pm 3^{\circ}\text{C}$ , the heater is switched on again and will continue heating up to  $15 \pm 3^{\circ}\text{C}$ .

This procedure is repeated until the ambient temperature on mirror remains above  $5 \pm 3^{\circ}\text{C}$  or when the key is turned into position 1 or 0.

### Power input

Cut-in current  $\leq 4$  amps

Continuous current  $\geq 1.5$  amps

A. Version without memory circuit (position memory)  
 Seat, backrest and head restraint adjustment

Standard version

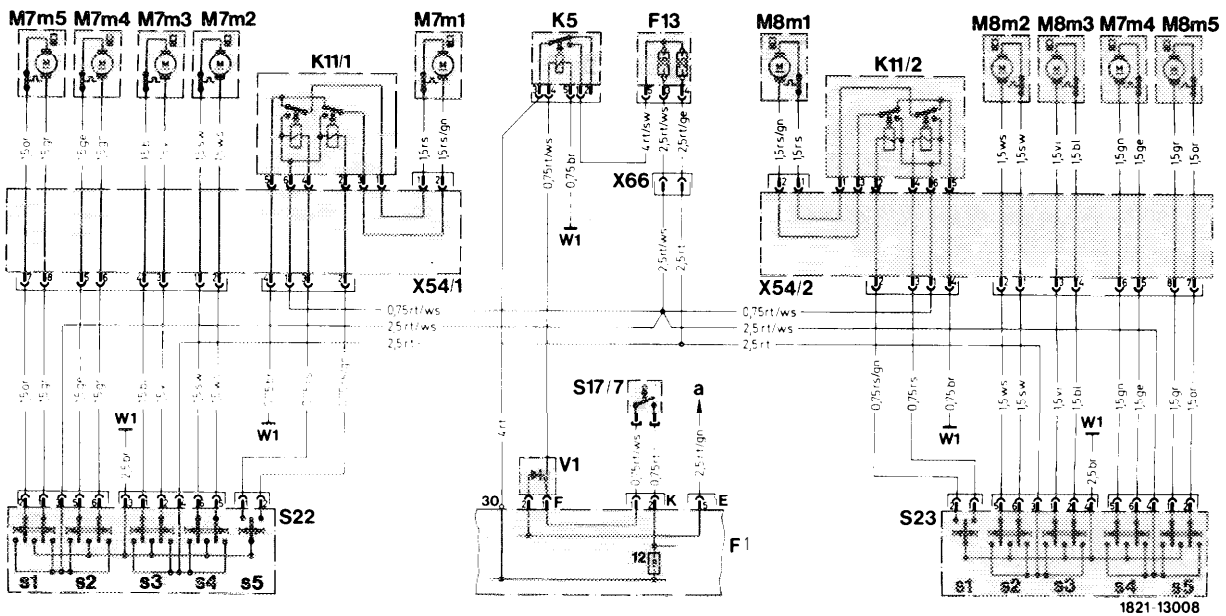

Wiring diagram electrical seat adjustment – seat at left and right (except@ )

- |       |   |       |   |
|-------|---|-------|---|
| F1    | Central electrical system                 | s22   | Switch seat adjustment front left                 |
| F13   | Auxiliary fuse box, seat adjustment       | S23   | Switch seat adjustment front right                |
| K5    | Relay seat adjustment                     | s1    | Head restraint high/low                           |
| K11/1 | Relay head restraint adjustment           | s2    | Seat height front                                 |
| K11/2 | Relay head restraint adjustment           | s3    | Seat forward/back                                 |
| M7    | Motor group seat adjustment, front left   | s4    | Seat height rear                                  |
| M8    | Motor group seat adjustment, front right  | s5    | Backrest  |
| m1    | Head restraint high/low                   | V1    | Diode seat adjustment comfort circuit             |
| m2    | Seat height front                         | W1    | Main ground (behind instrument cluster)           |
| m3    | Seat forward/back                         | x54/1 | Contact making strip seat adjustment, front left  |
| m4    | Seat height rear                          | X54/2 | Contact making strip seat adjustment, front right |
| m5    | Backrest                                  | X66   | Plug connection seat adjustment                   |
| S17/7 | Door contact switch comfort circuit, left | a     | To ignition starter switch S2/1 terminal 15 R     |



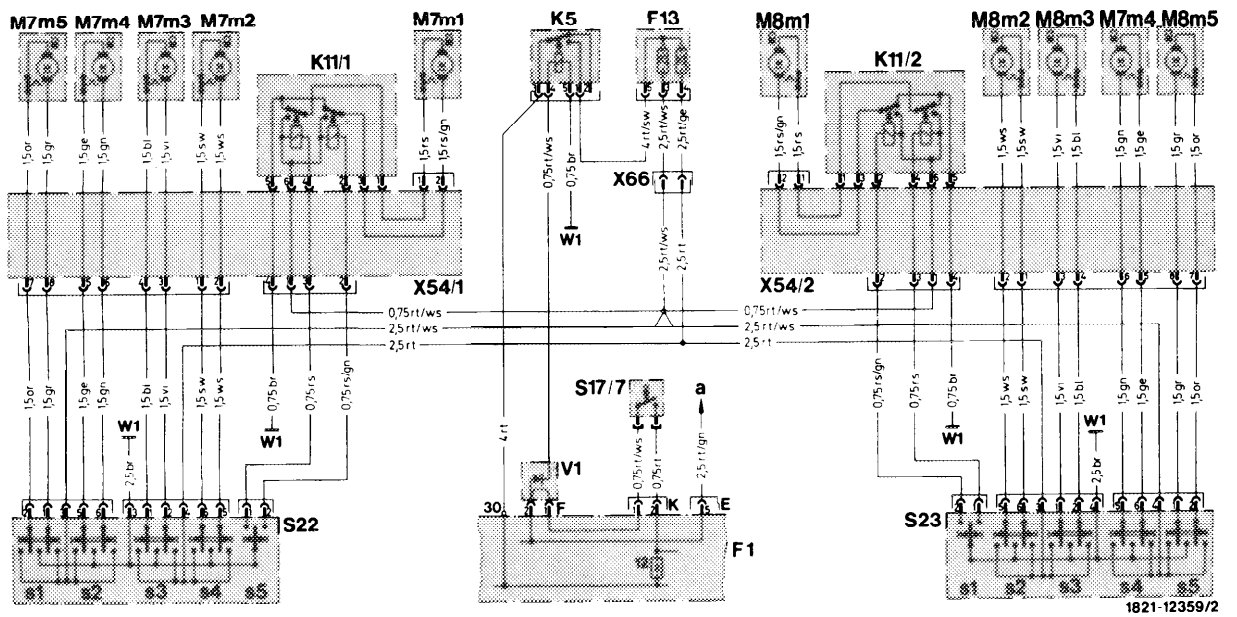

Wiring diagram electrical seat adjustment — seat left and right (USA)

## Operation

The seats are adjusted by means of a switch combination which is located in door lining.

Note: The harness is connected to switch by means of three plug couplings.

The switch can be removed without disassembly of door lining.

Switch, seat and head restraint adjustment

- 15 Switch
- d Head restraint high/low
- e Seat height front
- f Seat forward/back
- g Seat height rear
- h Backrest

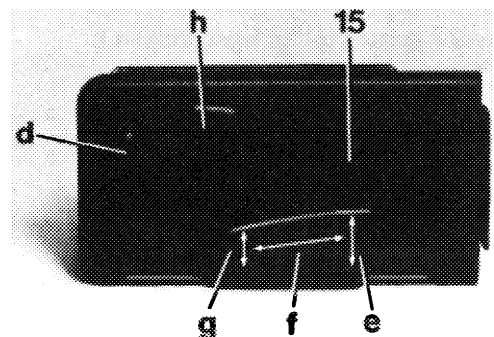

A group of three motors for longitudinal and height adjustment is located in seat frame.

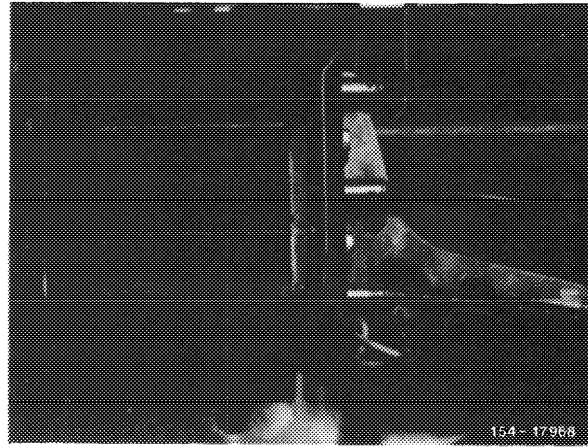

For adjustment, the motors are driving a gear unit (1) by means of 3 shafts.

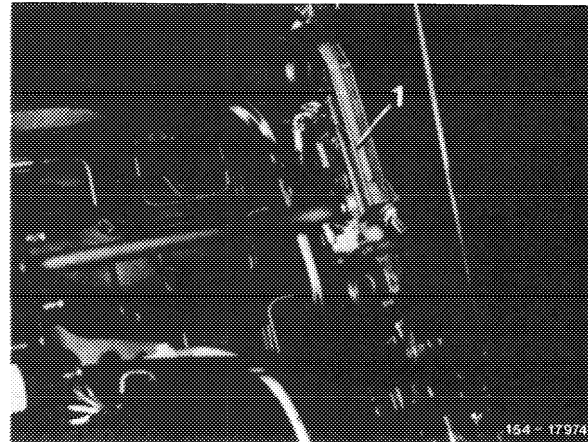

For backrest adjustment, the backrest frame is provided with an additional motor, which sets the backrest forward and back directly by means of a gear unit.

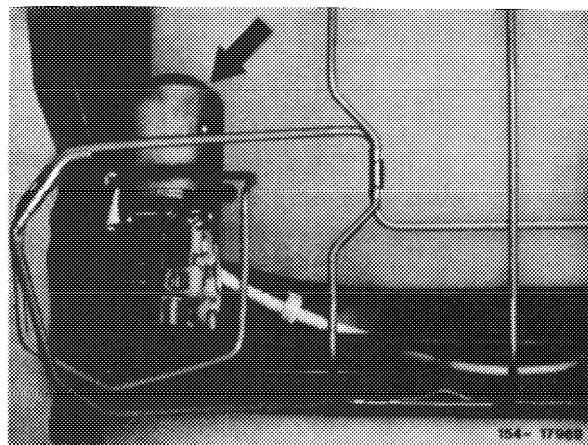

#### **Adjusting motor for head restraint**

The adjusting motor (14) for head restraint is located in backrest frame.

The head restraint is adjusted by means of a rack (20) which is driven by the motor by way of a shaft (21).

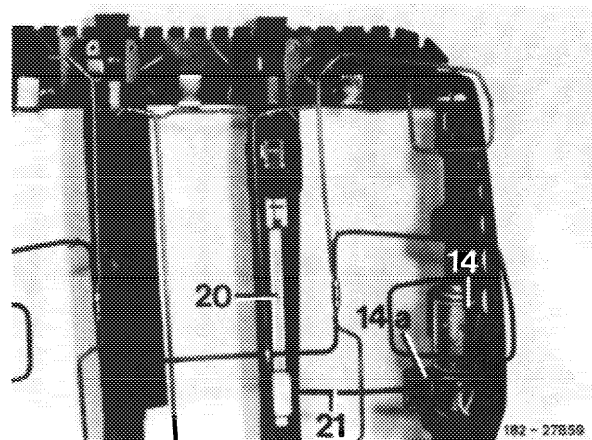

B. Version with memory circuit (position memory)  
 Seat, backrest and head restraint adjustment

Standard version

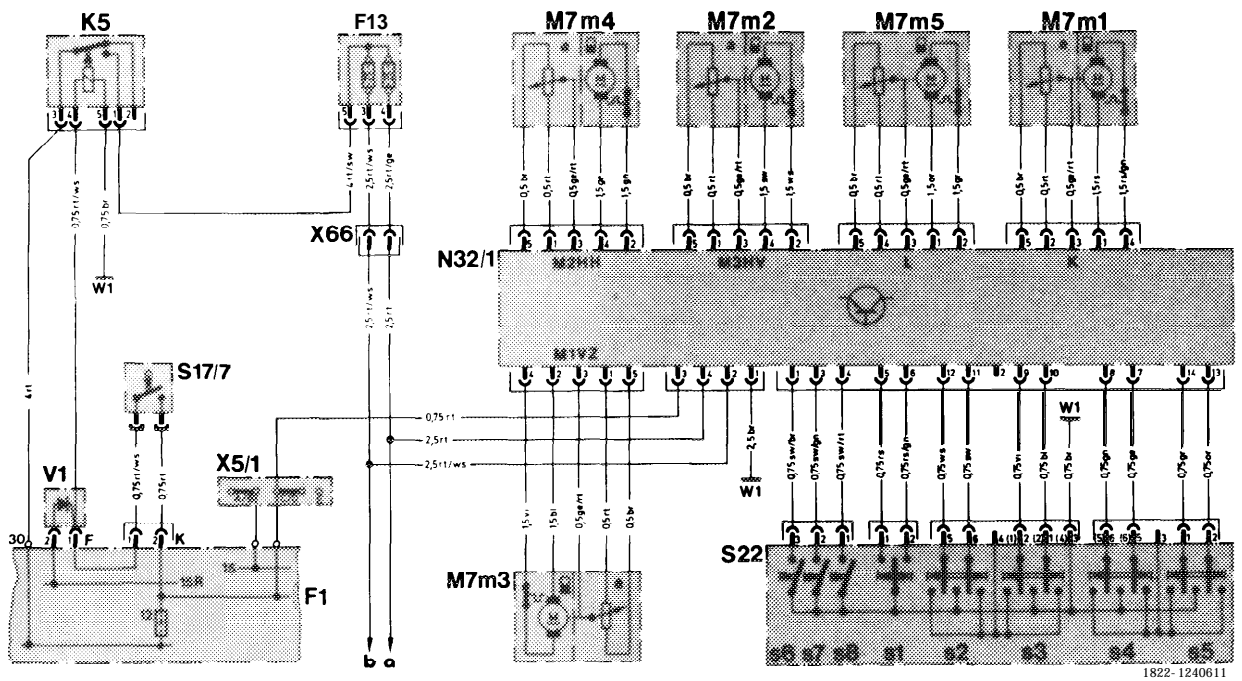

1822-1240611

Wiring diagram electrical seat adjustment with memory circuit left

- |       |  |      |   |
|-------|--|------|---|
| F1    | Central electrical system                                | V1   | Diode for seat adjustment comfort circuit         |
| F13   | Auxiliary fuse box, seat adjustment                      | W1   | Main ground (behind instrument cluster)           |
| K5    | Relay seat adjustment                                    | X5/1 | Line connector, interior                          |
| M7    | Motor group for seat adjustment, front left              | X66  | Plug connection for seat adjustment               |
| m1    | Head restraint high/low                                  | a    | To control unit N32/2 seat right connection No. 4 |
| m2    | Seat height front  | b    | To control unit N32/2 seat right connection No. 2 |
| m3    | Seat forward/back  |      | Deviation seat right:                             |
| m4    | Seat height rear   |      | Item S22: Connections indicated by brackets       |
| m5    | Backrest   |      |   |
| N31/1 | Control unit for seat adjustment with memory, front left |      |   |
| S17/7 | Door contact switch for comfort circuit, left            |      |   |
| s22   | Switch for seat adjustment, front left                   |      |   |
| s1    | Head restraint high/low                                  |      |   |
| s2    | Seat height front  |      |   |
| s3    | Seat forward/back  |      |   |
| s4    | Seat height rear   |      |   |
| s5    | Back rest  |      |   |
| s6    | Position button 1  |      |   |
| s7    | Position button 2  |      |   |
| s8    | Memory button  |      |   |

## Handling

---

The seat and head restraint adjustment can be operated by means of a switch in door lining in key position 1 and 2 or with opened driver's door.

Two seat positions and the respective head restraint positions can be put into memory and called whenever required.

### Switch, seat and head restraint adjustment

- 15 Switch
- a Position button 1
- b Position button 2
- c Memory button
- d Head restraint high/low
- e Seat height front
- f Seat forward/back
- g Seat height rear
- h Backrest

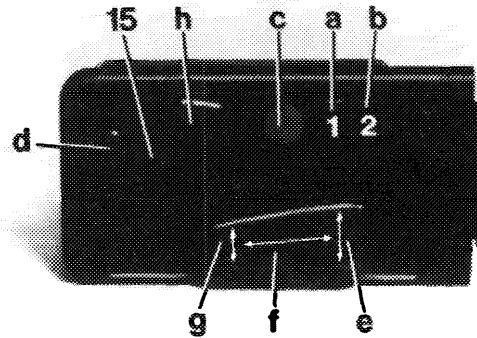

182-27370/1

### Memory for seat and head restraint position

- 1 Adjust position of seat and head restraint.
- 2 Push memory button (c).
- 3 Push position button 1 or 2.

The position button must be pushed within three seconds after pushing memory button (c), otherwise there will be no memory.

### Calling memory position (seat and head restraint)

- 4 Push position button 1 or 2.

For operational reasons, keep position button down until the end position is attained and none of the motors is rotating any longer.

The simultaneous actuation of several buttons will interrupt the adjusting sequence. A position in memory can be attained only after pushing a position button once again.

The electronic control unit (9) is located below on seat.

If the voltage supply to control unit is interrupted (e.g. by a disconnected battery) the memory is extinguished. The seat and head restraint position must be again put back into memory.

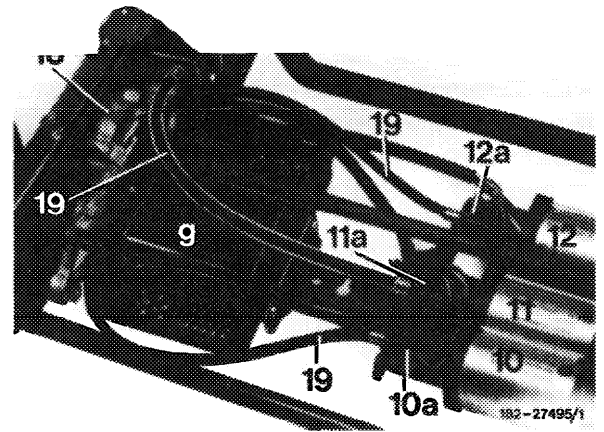

### Adjusting device

The seat is adjusted by a gear unit (18), which is driven by 3 motors (10, 11, 12) by means of 3 shafts (19). These parts are located below on seat.

The motors are each provided with a potentiometer (12a) as position transmitter for the memory. Depending on seat position, the potentiometer will transmit a given resistance value to memory of electronic control unit.

In the event of a defective potentiometer e.g. on motor of longitudinal adjustment, the longitudinal adjustment can no longer be put into memory. This will not impair adjustments.

The motors, shafts, potentiometers and gear units of seat adjustment are individually replaceable.

The backrest is adjusted by means of a motor (13) with integrated potentiometer and gear unit. The motor is located on backrest frame.

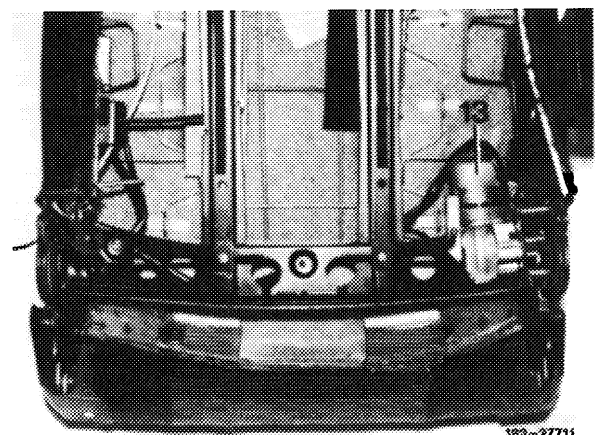

The adjusting motor (14) for head restraint is located in backrest frame.

The head restraint is driven by a rack (20), which in turn is operated by means of a motor and a shaft (21). A replaceable potentiometer (14a) is located on motor as position sensor.

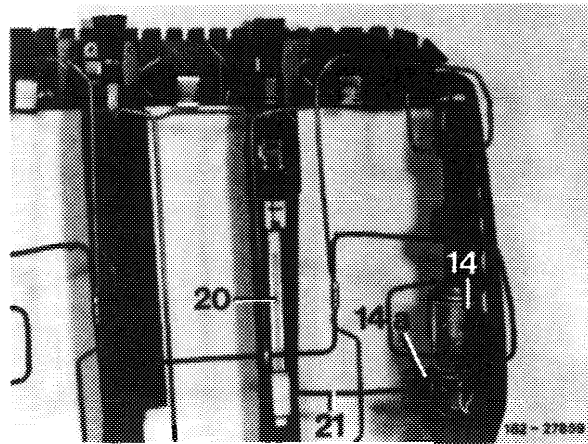

## 82–865 Removal and installation of switch for electrical seat adjustment

---

- 1 Disconnect negative terminal of battery.
- 2 Pull off handles (1, 2, 3) and fuse (4).

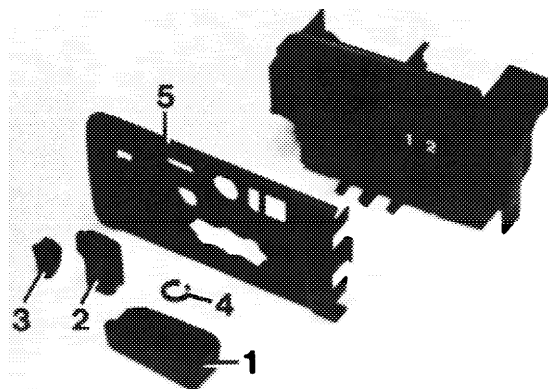

182 - 27862

- 3 Unclip cover (5) (arrow) and remove.

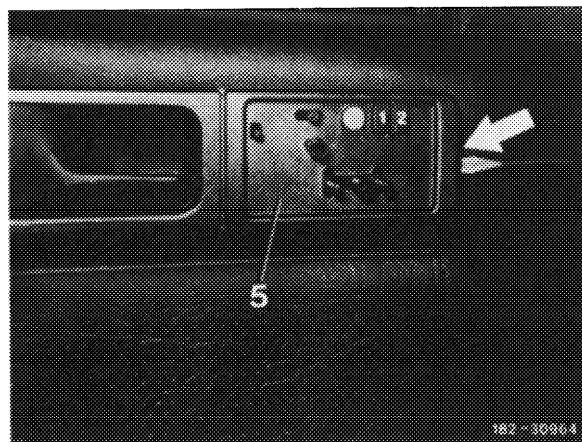

182 - 30963

- 4 Unscrew switches (arrows) and pull plug couplings of harness from switch.

- 5 Install switches in reverse order. Connect negative terminal of battery and check seat adjustment for function.

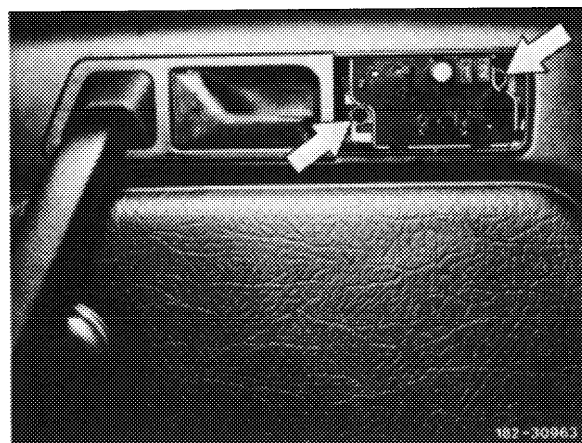

182 - 30963

Basic version starting September 1985  
starting 1986

### a) General information

#### Basic version

The EDW system is a contact-controlled system with an acoustic alarm signal. When triggered, the acoustic warning is sounded by an additional horn at approx. 30-second intervals.



The EDW system is a contact-controlled system with an acoustic and an optical alarm signal. When triggered, the acoustic warning is sounded by an additional horn at approx. 60-second intervals, and after an interval of approx. 30 seconds once again for 60 seconds.

In parallel with the above, the dimmer and the tail lamp will flash for approx. 150 seconds. If the parking (tail) or standing lamp is switched on when the alarm is triggered, only the dimmer light will flash.

#### Basic version

The system is combined with locking system and can be switched on and off only with master key (identification, red clip) on front lefthand and righthand door, as well as on trunk lid lock.

The locking cylinder and switch are one unit and can be replaced as a complete unit only.

The protective range includes the following vehicle components:

- All vehicle doors
- Brake (actuation)
- Engine hood and trunk lid
- Ignition (actuation, shorting)
- Radio (removal)
- One-sided level change of vehicle (towing-off protection)

#### Note

---

Owing to general operational safety, no interruption of ignition is provided for.

If the vehicle is transported on an automobile ferry or an automobile excursion train, or if it is parked on an elevator platform garage, do not switch on the anti-theft system, since it will then be unintentionally released. In such a case, lock vehicle with secondary key only.

#### Radio anti-theft protection

If the radio is removed with the anti-theft alarm system switched on, the unit will become unusable and will be operational again only upon reconditioning by Becker, the manufacturer.



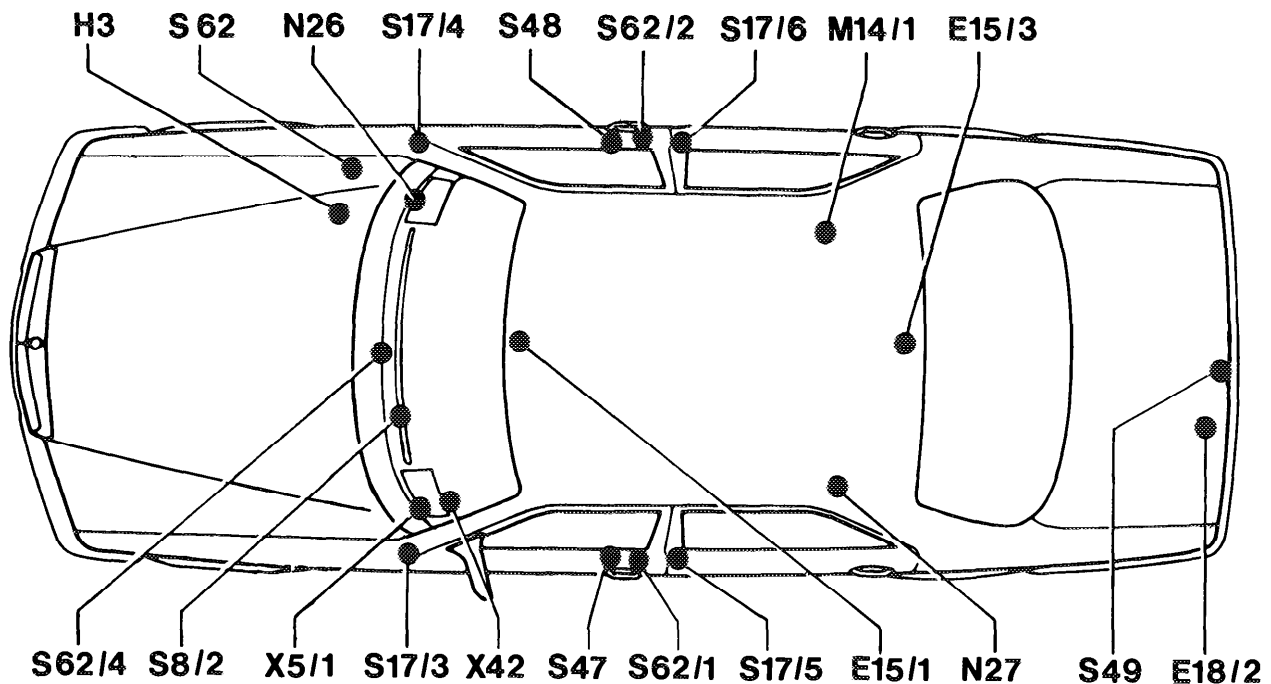

1824-13190/1

#### Layout

E15/1	Dome lamp with switch, front	s47	Switching and operating element, door front left
E15/3	Dome lamp, rear	S48	Switching and operating element, door front right
E18/2	Trunk light with switch	s49	Switching and operating element, trunk lid lock
H3	Alarm horn	S62	Switch engine hood EDW
M14/1	Supply pump central locking system	S62/1	Switch door EDW, front left (1-2 off, 1-3 on)
N26	Control unit EDW	S62/2	Switch door EDW, front right (1-2 off, 1-3 on)
N27	Release unit towing-off protection	S62/4	Locking contact EDW, radio
S8/2	Warning buzzer contact, light/central locking system	x5/1	Line connector, interior
S17/3	Door contact switch, front left	x37/1	Plug connection intermediate harness EDW, door front left, 3-pole
S17/4	Door contact switch, front right	X37/2	Plug connection intermediate harness EDW, door front right, S-pole
S17/5	Door contact switch, rear left	X42	Plug connection EDW front/EDW rear, 12-pole
S17/6	Door contact switch, rear right		

#### Vehicle keys

The following keys are included with EDW system:

**Main key**, 2 each — with angular handle and red clip. With this key, the vehicle can be completely operated, while the EDW system is switched „On” or „Off” via locking cylinder of front lefthand and righthand door, as well as via rear lock.

**Main key**, 1 each — as reserve key, sealed in transparent plastic sheeting.

**Secondary key**, 1 each -with rounded-off handle. With this key, the vehicle can be operated except for glove box and trunk lid lock. Note that in such a case the EDW system is **not** switched „On” or „Off”.

**Note:** Replacement keys are ordered similar to vehicles without EDW system according to code or lock number.

## b) Electric wiring diagrams

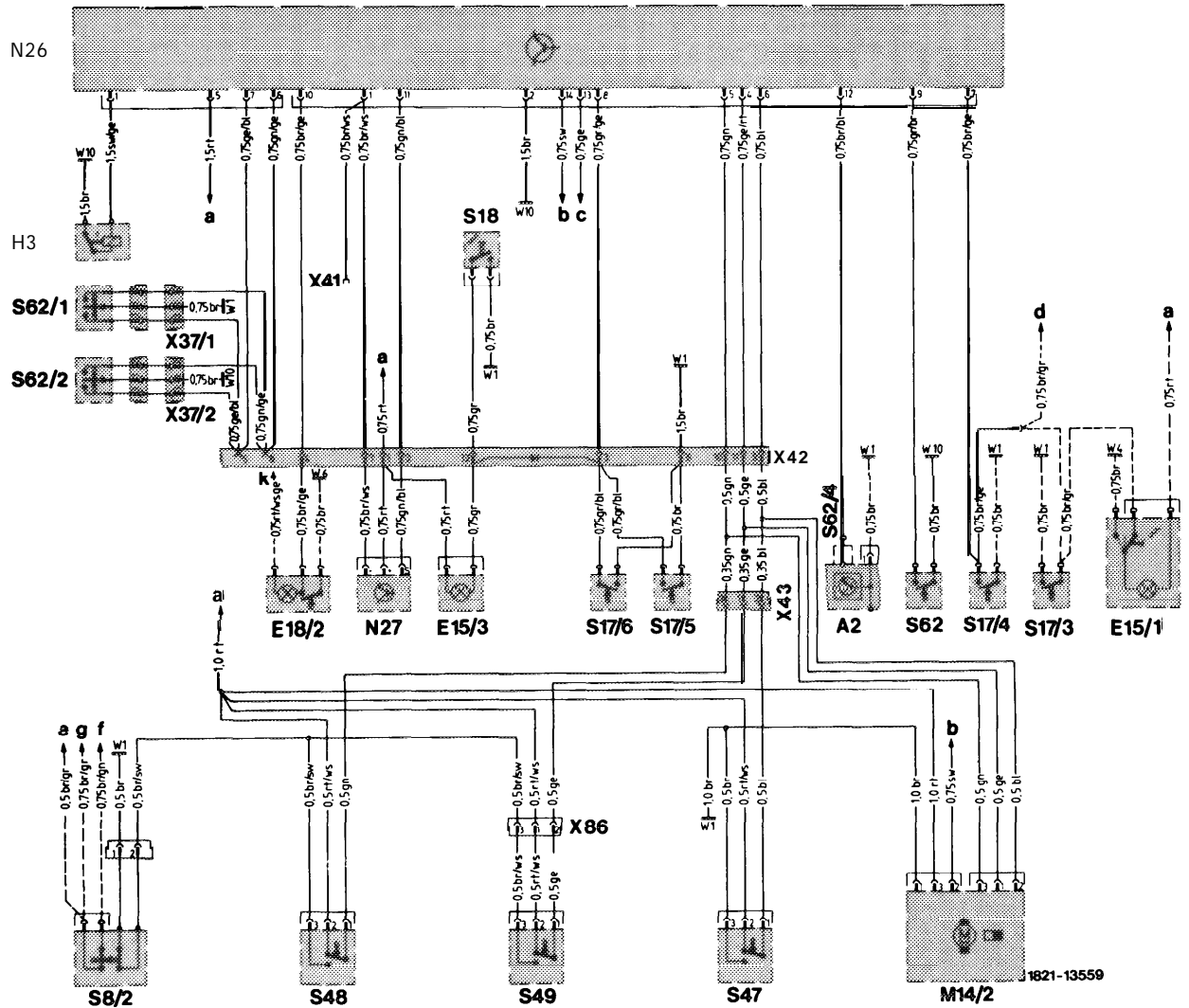

Wiring diagram basic version

— Main harness  
 --- Harness E DW system

A2 Radio  
 E15/1 Dome lamp with switch, front  
 E15/3 Dome lamp, rear  
 E18/2 Trunk light with switch  
 H3 Alarm horn  
 M14/2 Supply pump central locking system with orthopedic seat backrest, front  
 N26 Control unit EDW  
 N27 Releasing unit towing-off protection  
 S8/2 Warning buzzer contact, light/central locking system  
 S17/3 Door contact switch, front left  
 S17/4 Door contact switch, front right  
 S17/5 Door contact switch, rear left  
 S17/6 Door contact switch, rear right  
 S18 Switch dome lamp, rear  
 s47 Switching and operating element, door front left  
 S48 Switching and operating element, door front right  
 s49 Switching and operating element, trunk lid lock  
 S62 Switch engine hood EDW  
 S62/1 Switch for door EDW, front left (1-2 off, I-3 on)  
 S62/2 Switch for door EDW, front right (1-2 off, I-3 on)  
 S62/4 Locking contact EDW, radio

W1 Main ground (behind instrument cluster)  
 w4 Ground, dome lamp front  
 W6 Ground, trunk wheelhouse left  
 W10 Ground, battery  
 x37/1 Plug connection intermediate harness EDW, door front left, 3-pole  
 X37/2 Plug connection intermediate harness EDW, door front right, 3-pole  
 x41 Plug connection EDW connected ground  
 X42 Plug connection EDW front/EDW rear, 12-pole  
 x43 Plug connection EDW central locking system, S-pole  
 X44 Plug connection central locking system/ trunk lid lock  
 a Feed fuse 15 terminal 30 } Line connector  
 b Feed fuse 12 terminal 15 } Interior  
 c Feed stop lamp switch  
 d Warning buzzer contact  
 e Door contact switch, front right  
 f Warning buzzer  
 g Dome lamp, front



## c) Switching system on and off

### Switching on

When closing door front left or right, the switch (wiring diagram item S 62/1 or S 62/2) is simultaneously operated. The connected „negative“ on switch via brown line (connection No. 1) is connected to the yellow/blue line (connection No. 3) and is switched as an impulse to control unit (N 26, connection No. 7 of B-pole coupling). The system is in switched-on condition.

When the trunk is closed, the system is switched on by the switch element of central locking system at trunk lid lock. The „negative“ (line brown/white, connection No. 3) against switch element (S 49) is connected via 3-pole plug connection (X 43) with the yellow line of the 12-pole plug connection (X 42, connection No. 11) and is fed via yellow/red line to control unit (N 26, connection No. 4 of 14-pole coupling). The system is in switched-on condition.

When opening a door, the engine hood or the trunk lid, when removing the radio, when switching on or bridging the ignition lock or when actuating the service brake by way of the respective contact switch, the control unit is activated and the alarm is triggered.

If the level of the protected vehicle changes on one side, the alarm is also triggered.

An auxiliary unit developed as towing-off protection releases the alarm as follows:

- in the event of a level change of longitudinal axis by 2.2°
- in the event of a level change of transverse axis by 1.2°

that is, when the vehicle is raised, the alarm is triggered after max. 100 mm (measured on wheelhouse).

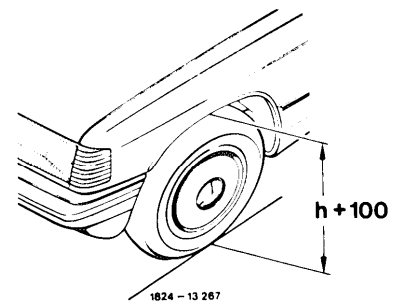

The system has a switching-on time delay of 15 seconds. If individual doors remain open for more than 15 seconds to remove items, after the system has been switched on, no alarm will be triggered at the end of the delay period. When the door is closed, this range is switched on, i.e. the alarm will be triggered when the door is opened again.

---

## Alarm signal

### Basic version

The alarm horn is activated by the control unit for approx. 30 seconds at intervals. The alarm of approx. 30 seconds will run off also when the releasing unit (e.g. the door) is immediately closed again.



The control unit activates the acoustic alarm signal for approx. 60 seconds at intervals and after a pause of approx. 30 seconds for another 60-seconds interval. The optical alarm signal flashes simultaneously for approx. 150 seconds. The alarm will also run off, when the releasing unit (e.g. the door) is immediately closed again,

### Switching off

When the door is opened at front left or right, the switch (wiring diagram item **S 62/1** or **S 62/2**) is simultaneously actuated. The „negative“ against switch via brown line (connection No. 1) is connected to green/yellow line (connection No. 2) and switched as an impulse to control unit (**N 26**, connection No. 6 of **8-pole** coupling). The system is in switched-off condition.

When the trunk is opened, the system is switched off by the switching element of the central locking system on trunk lid lock. The „positive“ (line red/white, connection No. 1) against switch element (**S 49**) is connected via the 3-pole plug connections (**X44/1** and **X 43**) with the yellow line of the **12-pole** plug connection (**X 42**, connection No. 11) and fed via yellow/red line to control unit (**N 26**, connection No. 4 of **14-pole** coupling). The system is in switched-off condition.

**d) Layout of components**

**Control unit  
(in legroom right, under foot support)**

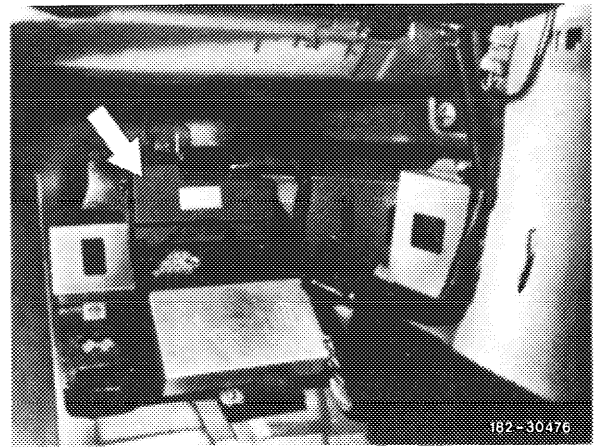

**5 Switch on locking cylinder  
6 Assembly tool**

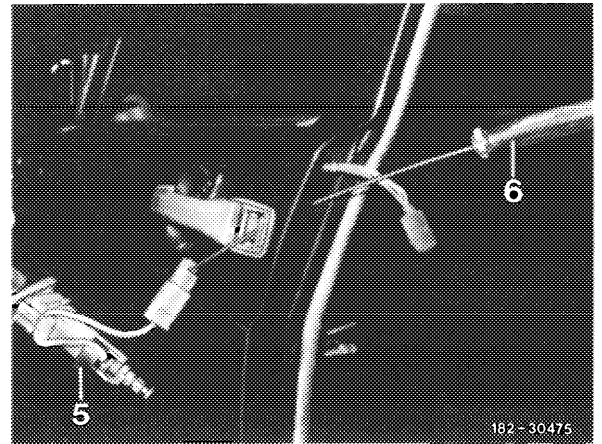

**4 Plug connection, 3-pole  
7 Cover**

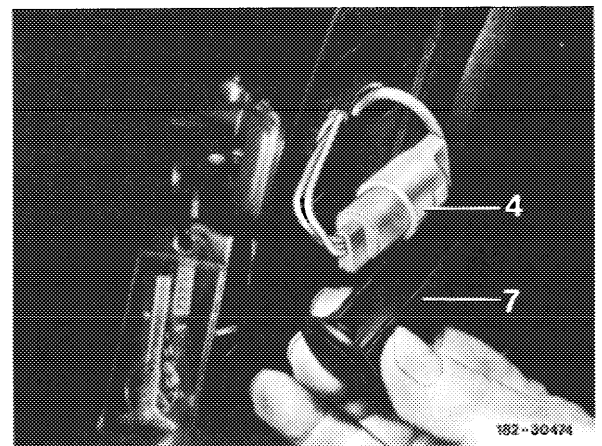

**Release unit towing-off protection**

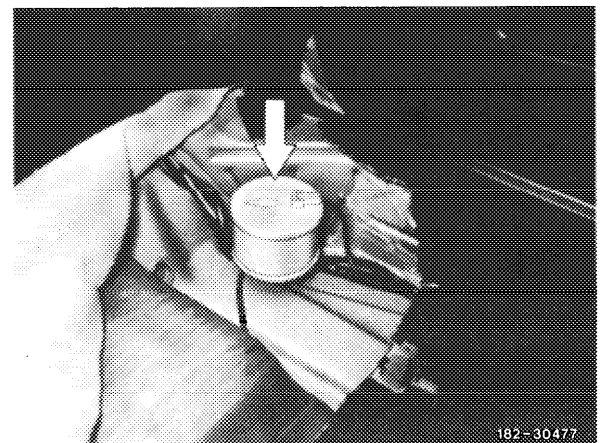

- 1 Plug connection EDW front/EDW rear
- 2 Line connector, interior

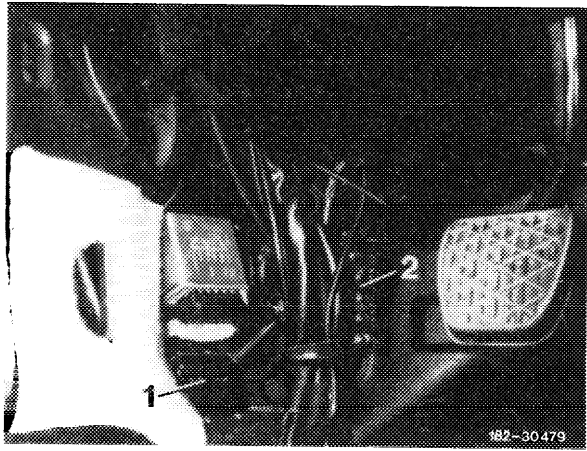

Additional fuse box EDW  
(USA only)

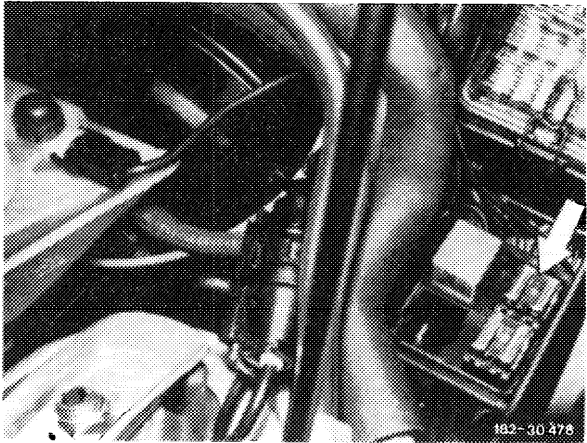

Fuse contact, radio

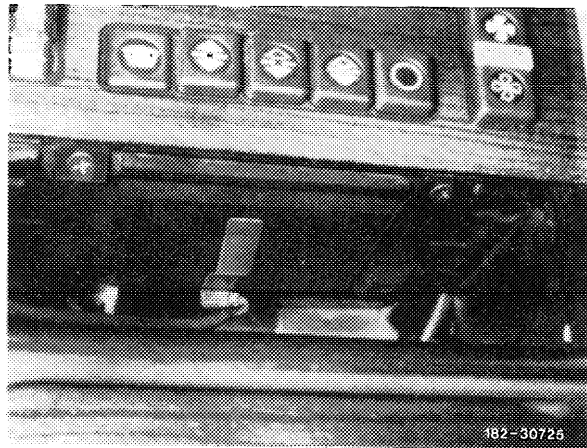

- (USA)
- S62 Switch, engine hood
- H3 Alarm horn

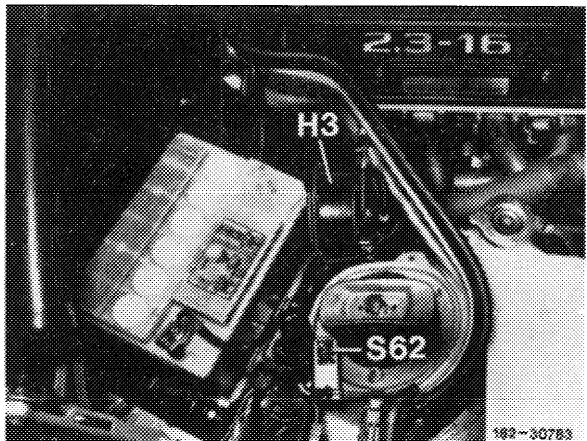

Basic version  
S62 Switch, engine hood  
H3 Alarm horn

