

Specified SAE viscosity classes during continuous ambient temperatures

Following the SAE grades exactly according to the ambient air temperatures would result in frequent engine oil changes. The temperature ranges for the SAE grades should therefore be regarded as a guideline which may be exceeded for brief periods.

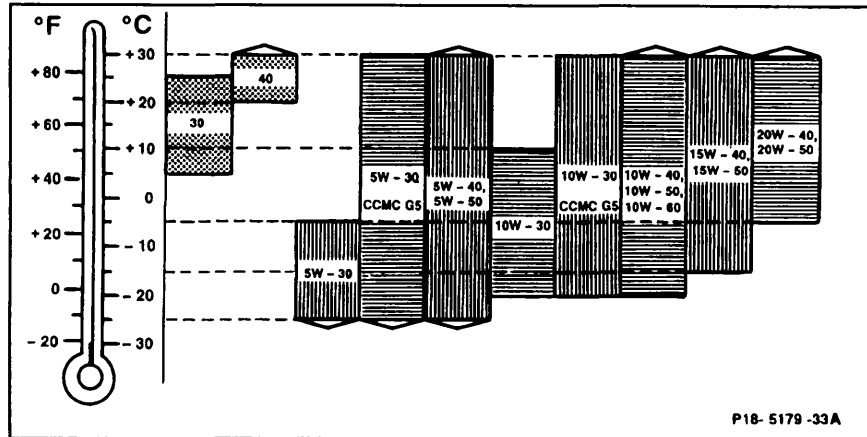

Oil capacity in liters

Engine	102.961	102.983
Total capacity during oil and filter change	4.5	5.0
Oil pan	4.3	4.8
Oil dipstick color code	light blue	gray

Torque specifications (Nm)

Oil pan drain plug	30	25
Center bolt, oil filter cover	25	25

Special tools

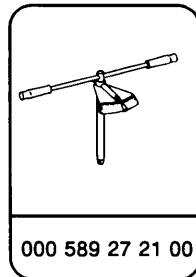
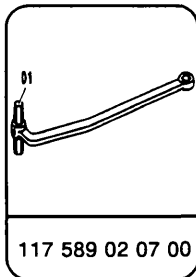

- Before suctioning or draining engine oil, drain oil filter, by unscrewing center bolt and removing together with oil filter cover.
- Suction engine oil via oil dipstick tube with engine at operating temperature.

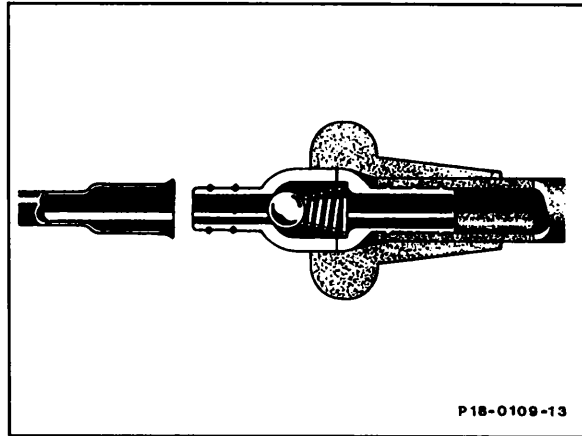

If no suction unit is available:

- Drain engine oil from oil pan (arrow).

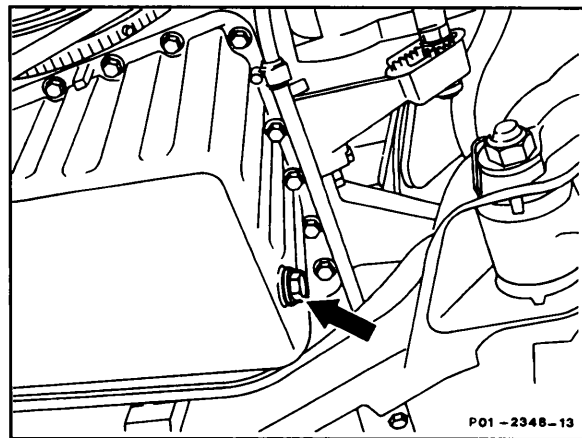

- Replace filter element.

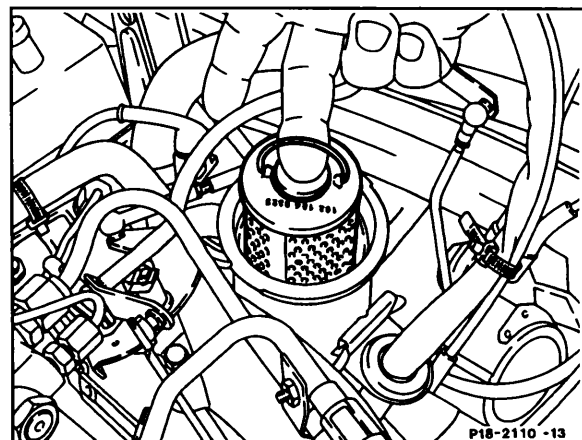

- Replace rubber seal ring (1) on cover.
- Check seal ring (2) on center bolt and replace as appropriate.

NOTE: There are two oil filter versions which differ in cover and rubber seal ring diameter and in thickness of rubber seal ring.

Use care not to use the incorrect rubber seal ring (1).

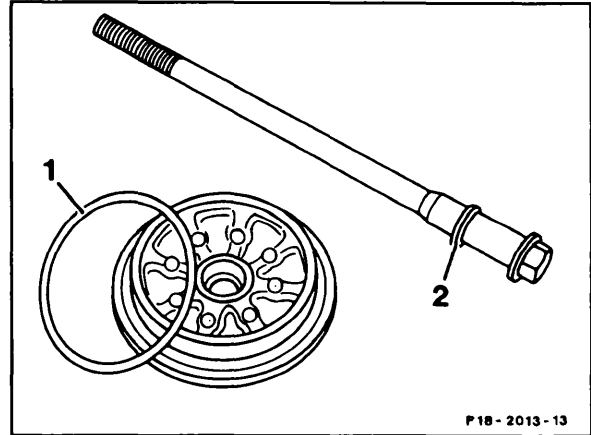

- Torque center bolt to 25 Nm with torque wrench.

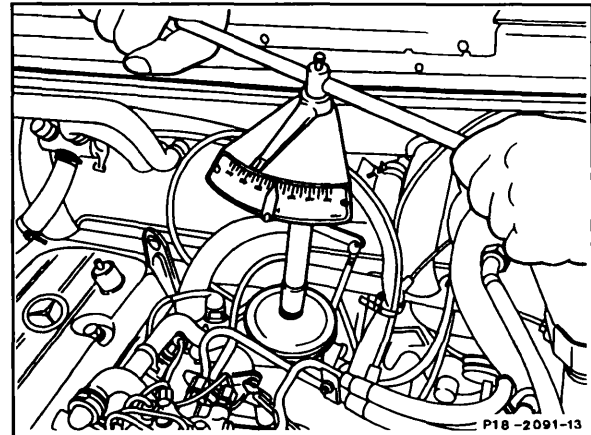

- If oil has been drained from oil pan, replace seal ring on drain plug.
- Tighten oil drain plug to 30 Nm, or for engine 102.983 to 25 Nm.
- Add engine oil.
- Run engine and check for leaks.
- Check oil level approx. 2 min. after stopping engine at operating temperature.

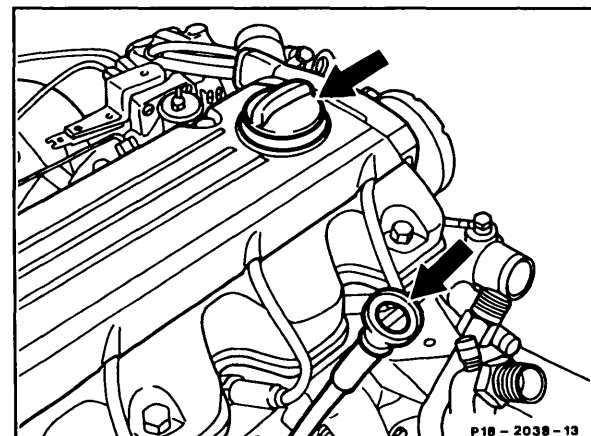

Specified SAE viscosity classes during continuous ambient temperatures

Following the SAE grades exactly according to the ambient air temperatures would result in frequent engine oil changes. The temperature ranges for the SAE grades should therefore be regarded as a guideline which may be exceeded for brief periods.

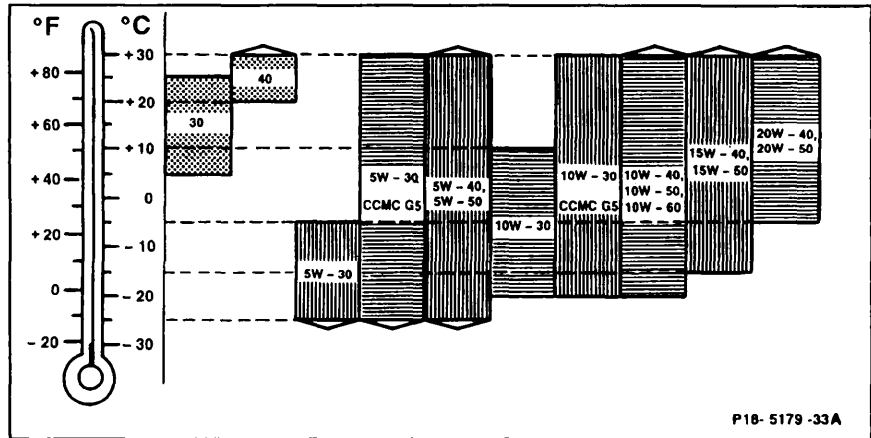

Oil capacity in liters

Engine	Model	Total capacity during oil and filter change	Oil dipstick identification	
			Oil dipstick color code	Identification on dipstick handle
102	201	5.0	gray	-
103	124, 126, 201	6.0	red	-
103	124 4MATIC	6.5	red	-
104	124, 129	7.5	-	10407
104	140	7.5	-	60322

Torque specifications (Nm)

	Engine	Nm
Oil pan drain plug	all	25
Spin on oil filter	102, 103	20
Threaded cover	104	20

Special tools

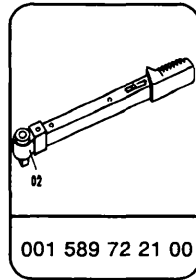
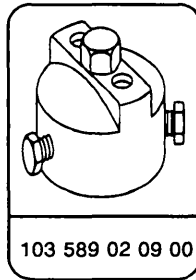
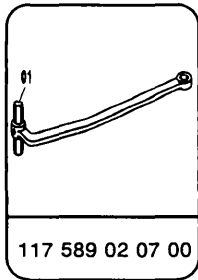

NOTE: Change engine oil only with engine at operating temperature.

Removing old oil filter

Engine 102 and 103

- Before suctioning or draining engine oil, unscrew spin-on filter with socket wrench insert 74 mm (arrow). Apply a light seating blow against socket wrench insert, so that it is tightly seated on filter.

While unscrewing, some oil may run out until the check valves in oil filter cartridge close.

For this reason, hold or place a suitable rag under mounting surface at bottom of oil filter.

Note: If the spin on oil filter cannot be loosened with the socket wrench element, remove the air cleaner and drive in a screwdriver or other suitable tool to provide leverage to remove the oil filter.

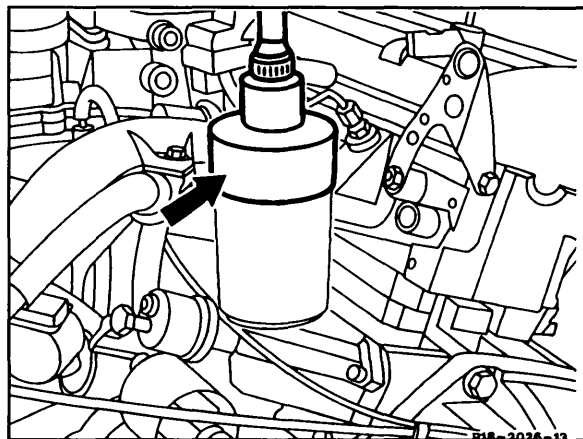

Engine 102

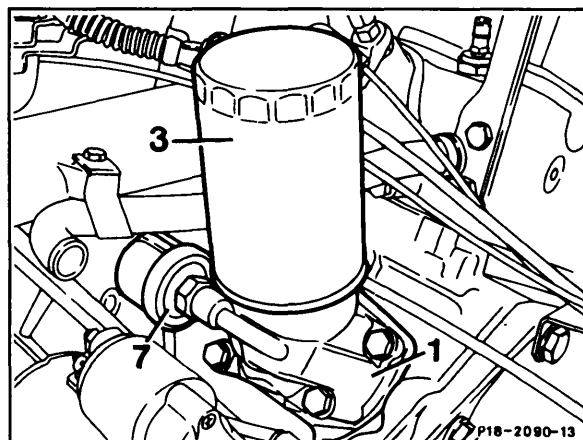

Engine 103

Engine 104

- Prior to suctioning or draining of engine oil, unscrew screw cover (2) with socket wrench element 74 mm.
 - Remove threaded cover (2) with oil filter element (4).
- On Model 140, remove air filter and replace after installing oil filter cartridge.

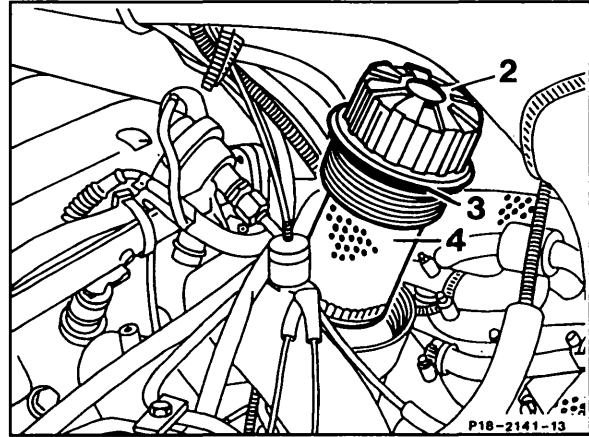

Engine 104

Removing old oil

Engine 102, 103, 104

- Suction engine oil via dipstick tube with engine at operating temperature.

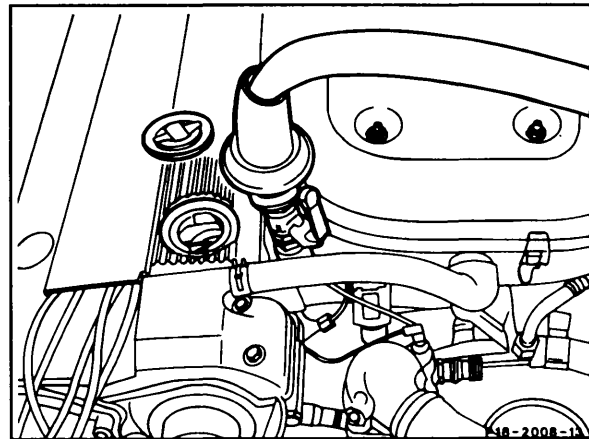

Engine 104

If no suction unit is available:

- Drain engine oil from oil pan (arrow).

First remove engine compartment lower panel and reinstall upon completion of maintenance jobs.

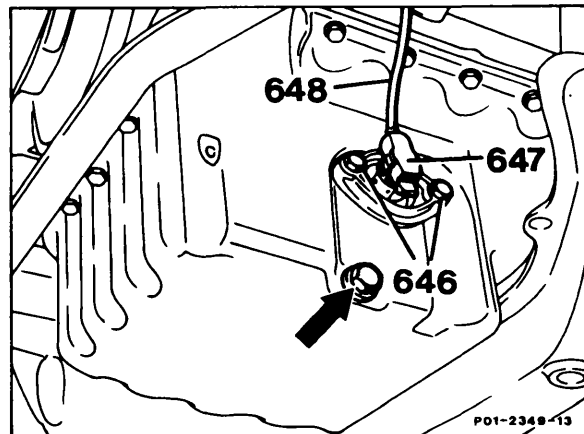

Engine 102

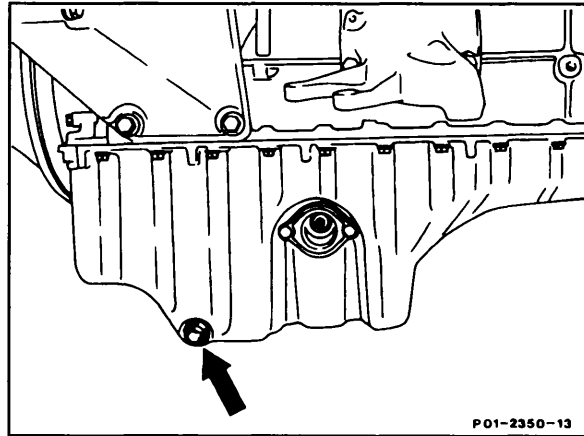

Engine 103,104

- On 4MATIC vehicles open drain plug (5) on large oil pan (4) only.
- If the oil has been drained out of oil pan, replace seal ring on oil drain plug.
- Tighten oil drain plug to 25 Nm.

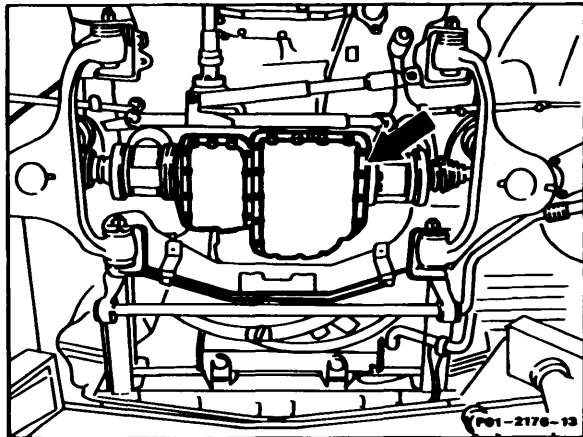

Engine 103 4MATIC

Installing new oil filter

Engine 102 and 103

- Clean mating surface (arrow) on oil filter mounting flange.

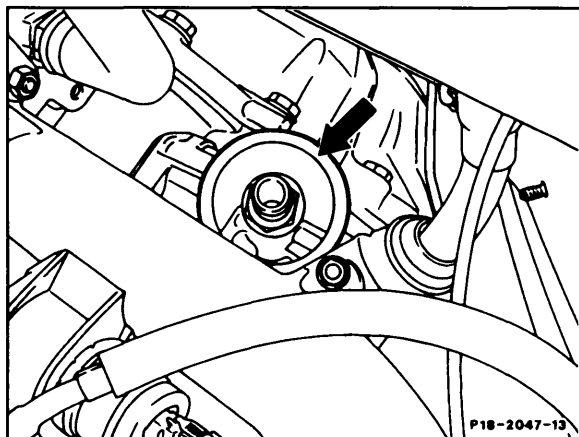

- Slightly lubricate gasket (arrows) on new spin-on filter.

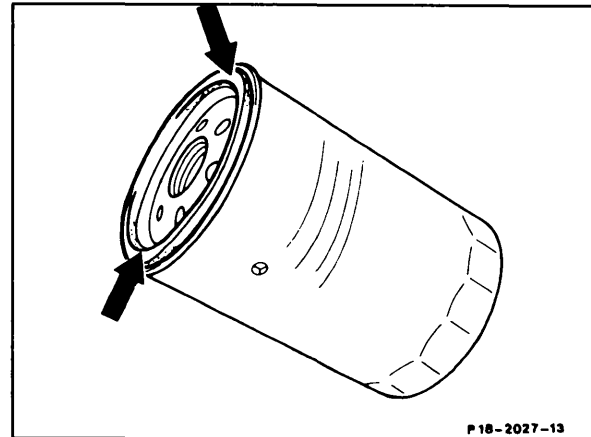

- Screw on filter and tighten by hand.

Then turn filter with 74 mm socket wrench element (arrow) an additional 1/4 turn (90°) (20Nm).

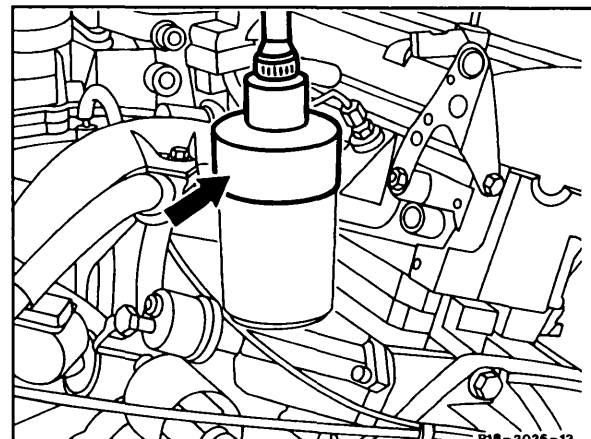

Engine 104

- Replace seal ring (3).
- Insert oil filter element (4) into threaded cover (2).
- Insert threaded cover with oil filter element and tighten to 20 Nm.

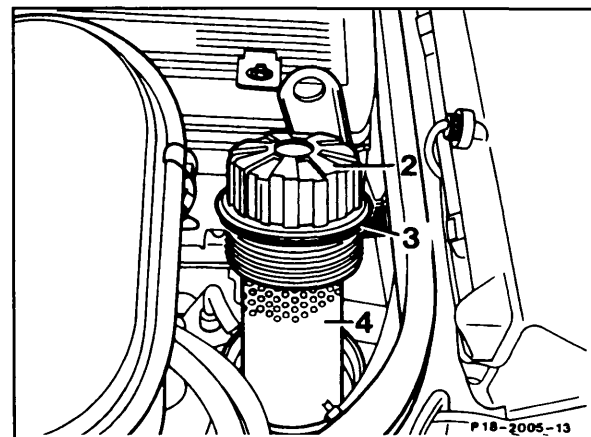

Filling engine oil

- Add engine oil (arrow).
- Run engine and check for leaks.
- Check oil level (arrow) approx. 2 minutes after shutting off engine at operating temperature.

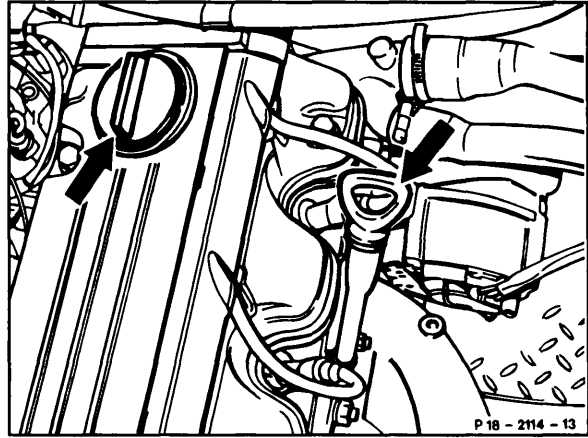

Engine 102

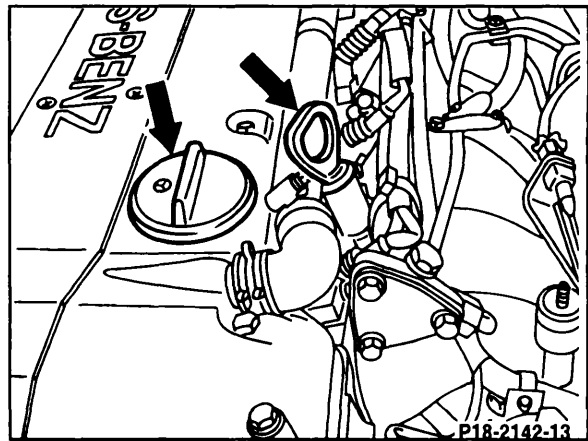

Engine 103 and 104

Specified SAE viscosity classes during continuous ambient temperatures

Following the SAE grades exactly according to the ambient air temperatures would result in frequent engine oil changes. The temperature ranges for the SAE grades should therefore be regarded as a guideline which may be exceeded for brief periods.

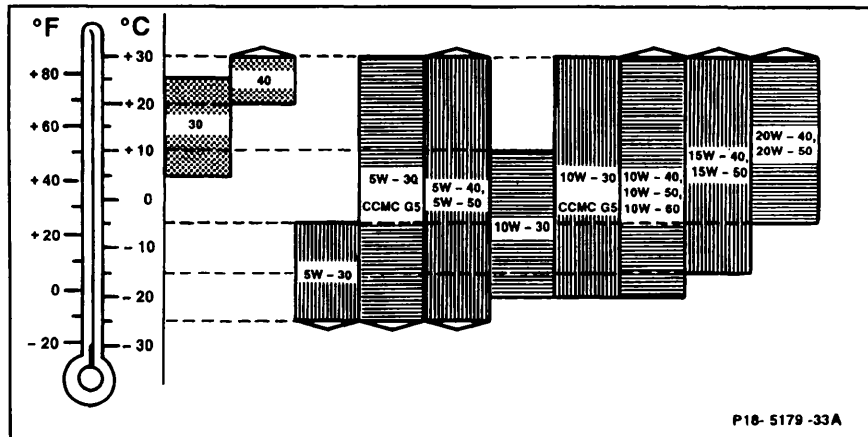

Oil capacity in liters

Oil dipstick color code	pink burgundy	yellow/green
Total capacity during oil and filter change	6.5	6.0
Oil pan	6.0	5.5

Torque specifications (Nm)

Oil pan drain plug	40
Center bolt, oil filter cover	35

Special tools

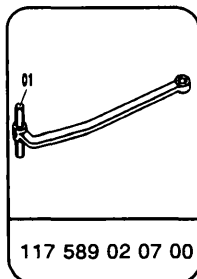

- Suction engine oil via oil dipstick tube with engine at operating temperature.

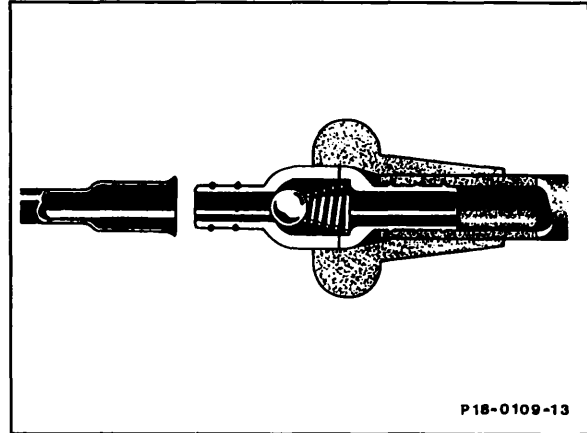

If no suction unit is available:

- Drain engine oil from oil pan (arrow).

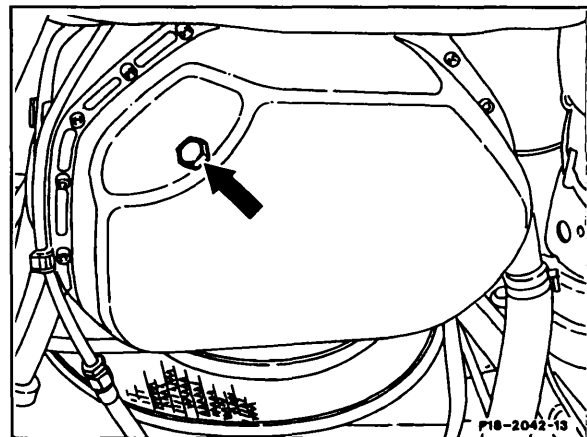

- Unscrew and empty oil filter lower half (3).
- Wash and blow out oil filter lower half.
- Check sealing ring (2) and replace as necessary.

For this purpose, pull compression spring together with spring retainer (5) off fastening screw (1). Make sure that the compression spring and retainer is correctly installed during assembly.

- Replace rubber sealing ring (4).
- Install oil filter lower half with a new filter element (6) and torque fastening screw (1) to 35 Nm.

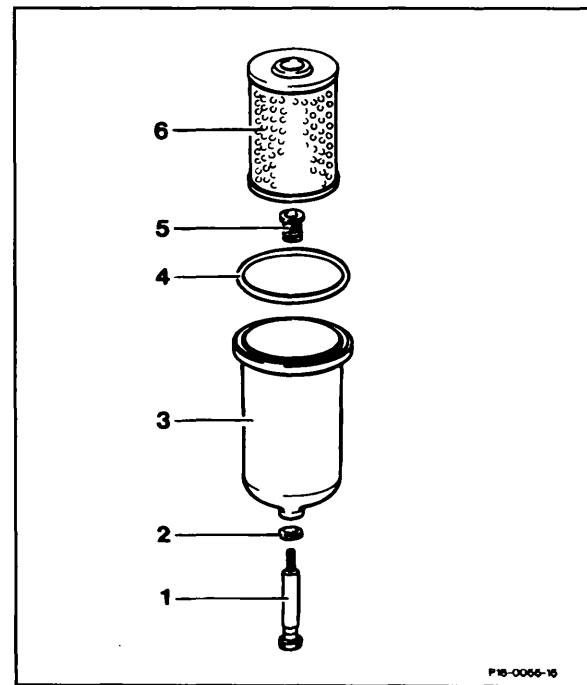

- If oil has been drained from oil pan, replace sealing ring on drain plug.
- Torque oil drain plug to 40 Nm.
- Add engine oil.
- Run engine and check for leaks.
- Check oil level approx. 2 min. after stopping engine at operating temperature.

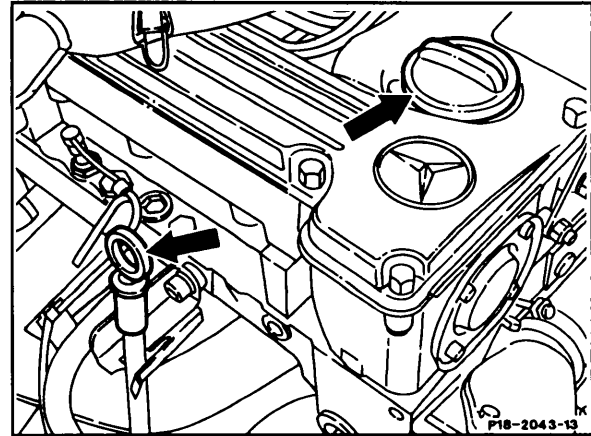

Engine 110

Specified SAE viscosity classes during continuous ambient temperatures

Following the SAE grades exactly according to the ambient air temperatures would result in frequent engine oil changes. The temperature ranges for the SAE grades should therefore be regarded as a guideline which may be exceeded for brief periods.

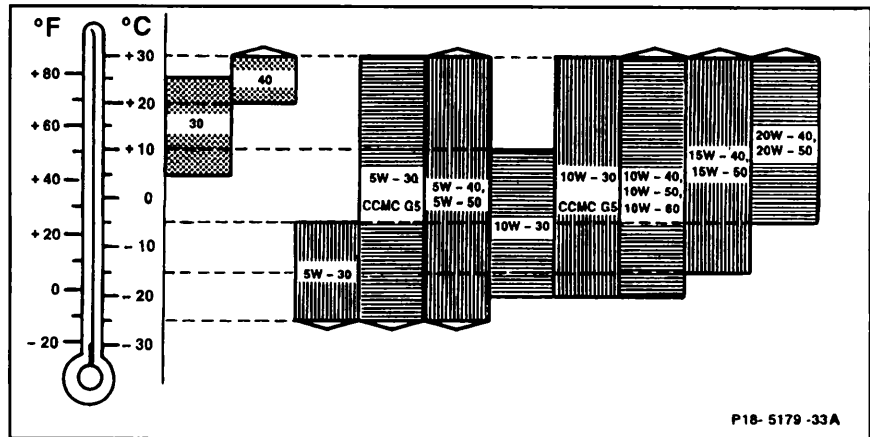

Oil capacity in liters

Engine	Model	Total capacity during oil and filter change	Dipstick identification		
			color code	color code	identification number (red color)
			round handle	bottle opener shaped handle	
116, 117	107	8	blue	-	-
116, 117	126	8	light blue gray	gray	-
119	124, 129, 140	8	-	gray	-
120	140	10	-	-	12010

Torque specifications (Nm)

Model	107	126	124, 129, 140
Oil pan drain plug	50	40	40
Center bolt, oil filter cover	-	25	20
Center bolt, oil filter lower housing	25	-	-
Threaded cover (Engine 120)	-	-	20

Special tools

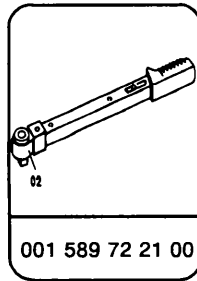
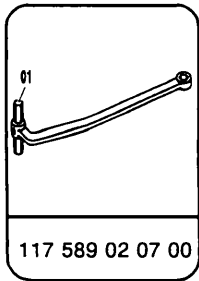

Removing old oil filter

Engine 116, 117 In model 126
 Engine 119 In model 124, 129, 140

- Remove flexible air duct (arrow).

Engine 116, 117

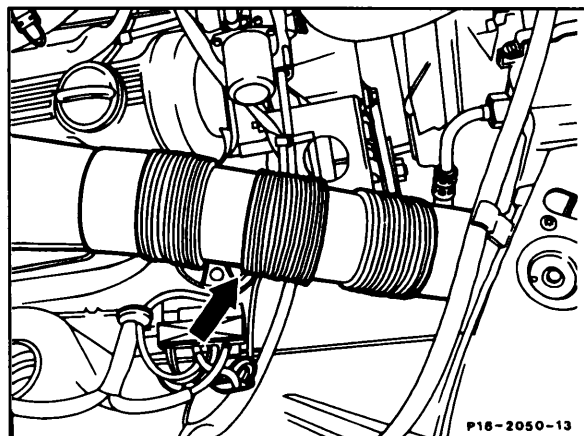

Engine 119

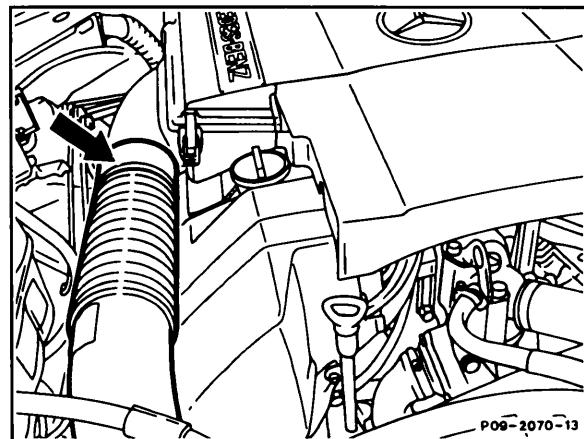

Engine 120

- Remove left air filter housing and mass air flow sensor as an assembly (job no. 09-0015).

Engine 120

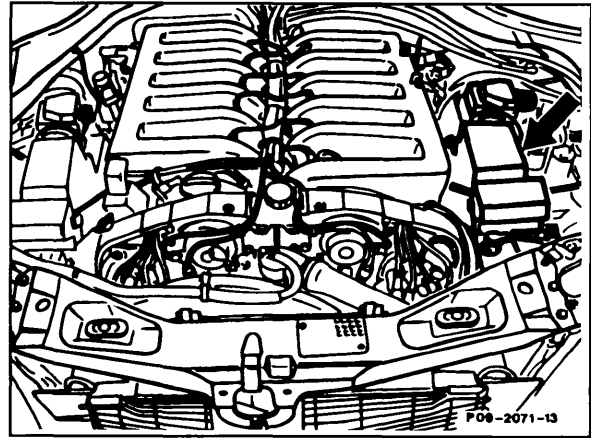

Removing old oil

NOTE: Change engine oil only with engine at operating temperature.

Engine 116, 117 in model 126

Engine 119 in model 124, 129, 140

- Drain oil filter prior to suctioning or draining engine oil. For this purpose, loosen center screw (1) and remove together with oil filter cover.

Engine 116, 117 in model 126

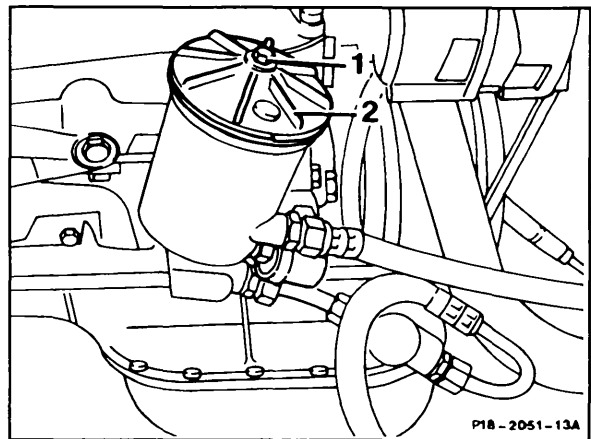

Engine 119

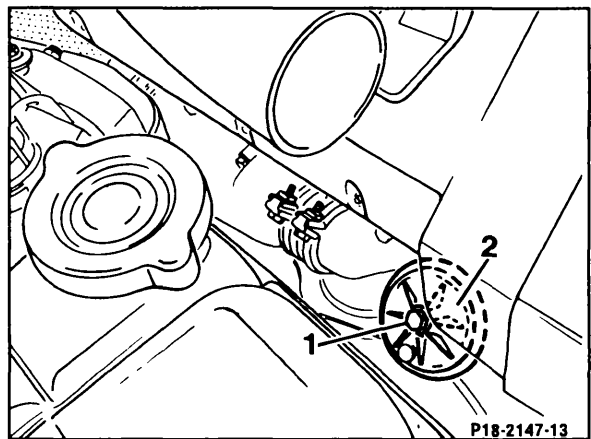

Engine 120 in model 140

- Before suctioning or draining engine oil, remove threaded cover (2) using 74 mm insert.
- Remove threaded cover (2) and oil filter cartridge (4).

Engine 120

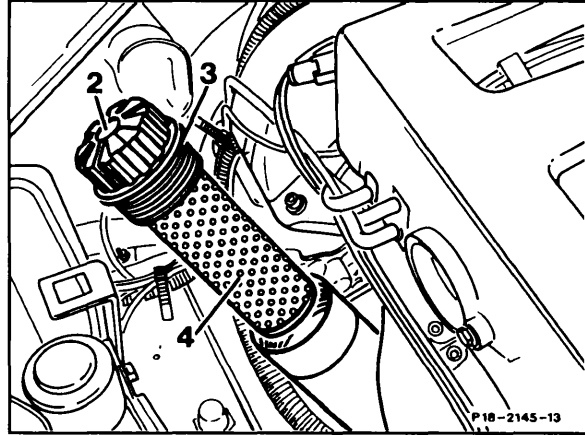

All Engines

- Suction engine oil via oil dipstick tube with engine at operating temperature.

Engine 119 in model 129

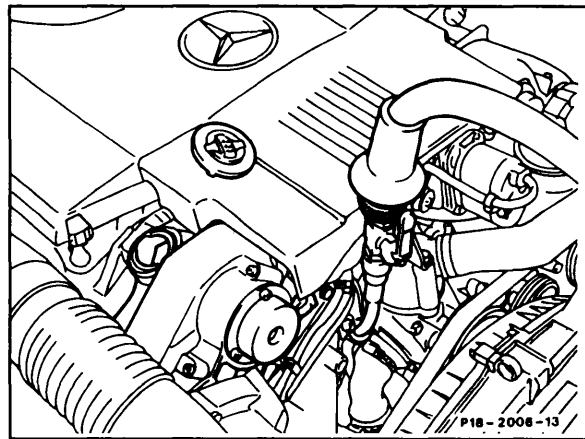

If no suction unit is available:

- Drain engine oil from oil pan (arrow).

Model 107

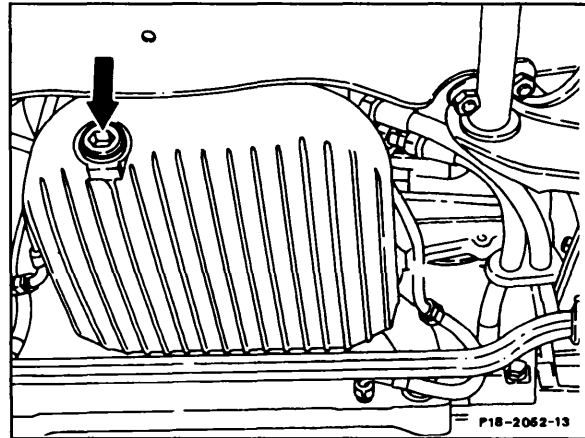

Model 126, 129

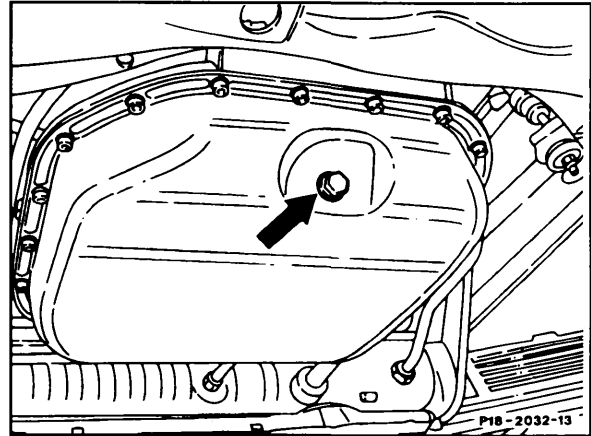

Model 140

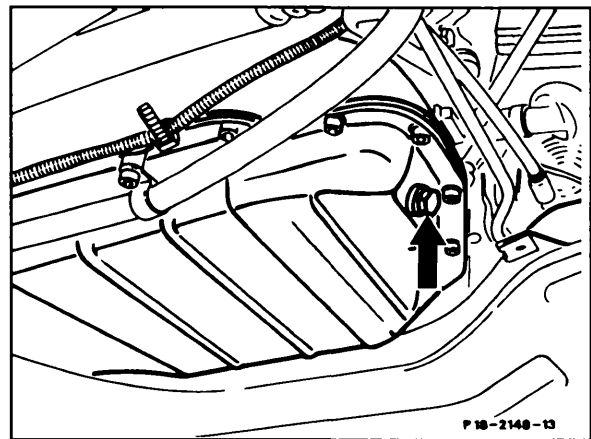

- On model 129 and 140, remove engine compartment lower panel first and reinstall after completing maintenance jobs (refer to job item 6190).
- If the oil has been drained from oil pan, replace seal ring on oil drain plug.
- Tighten oil drain plug. Refer to table for correct torque.

Installing new oil filter

Engine 116, 117 in model 107

- Unscrew oil filter housing (3) and drain.
- Wash out oil filter housing and blow out.
- Check seal ring (2) and replace as necessary.

For this purpose, pull compression spring with spring washer (5) from fastening screw (1). **Be sure to properly install compression spring with spring washer during assembly.**

- Replace rubber seal ring (4).
- Install oil filter lower part with a **new** filter element (6) and tighten fastening screw (1) to 25 Nm.

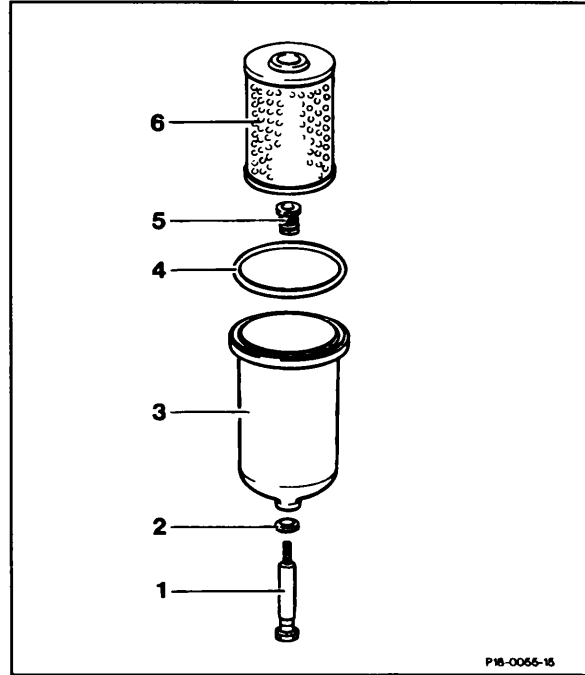

Engine 116, 117 in model 107

Engine 116, 117 in model 126 Engine 119 in model 124, 129, 140

- Replace filter element while making sure that the large rubber seal (24 mm ID) points in downward direction.

Engine 116, 117 in model 126

- Replace rubber seal ring (1) on cover.
- Check seal ring (2) on center screw and replace as necessary.
- Tighten center screw to 25 Nm.

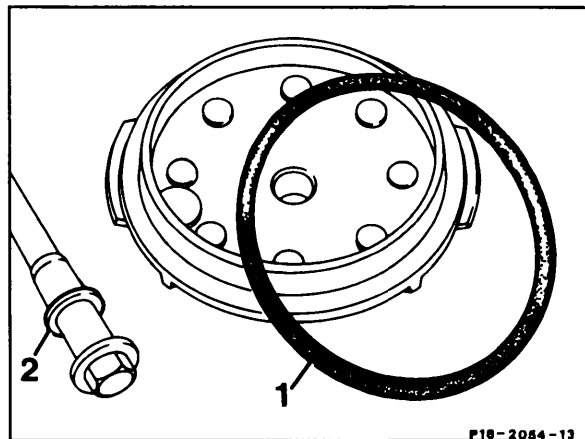

Engine 116, 117 in model 126

Engine 119 In model 124, 129, 140

Replace rubber seal rings (4 and 4a) on cover.

- Tighten center screw to 20 Nm.

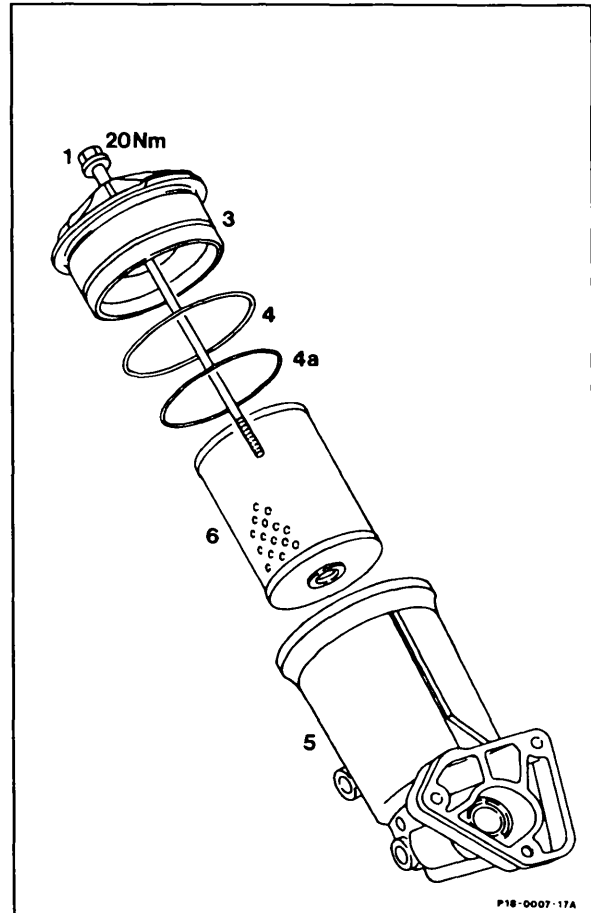

Engine 119

Engine 120 In model 140

- Replace seal (3).
- Insert oil filter cartridge (4) in threaded cover (2).
- Insert cartridge with cover and tighten.
- Install left air filter housing and mass air flow sensor assembly.

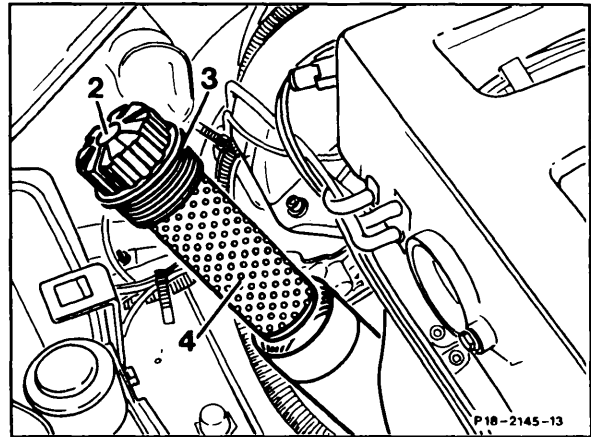

Engine 120

Filling engine oil

All engines

- Add engine oil (arrow).
- Run engine and check for leaks.
- Check oil level with engine at operating temperature approx. 2 minutes after stopping engine (arrow).

Engine 116, 117 in model 107, 126

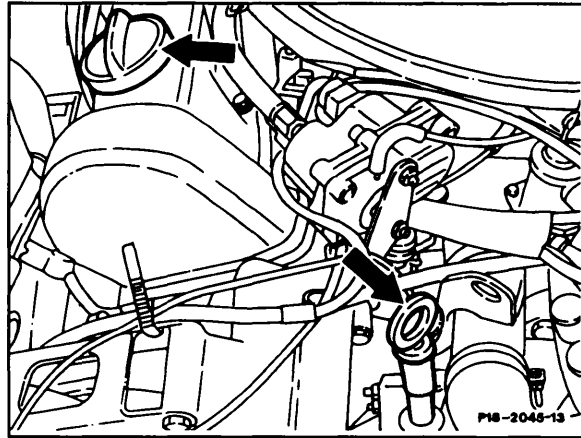

Engine 119 in model 129

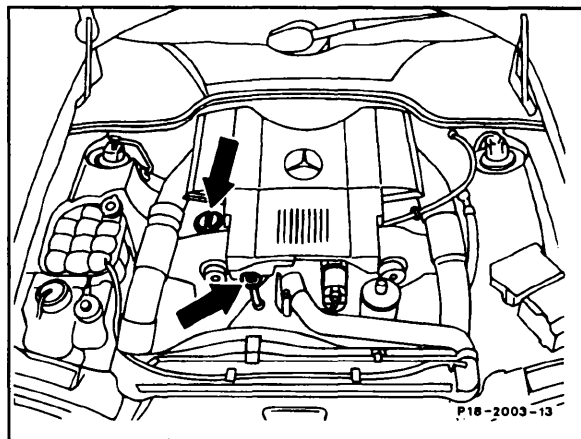

Engine 120 in model 140

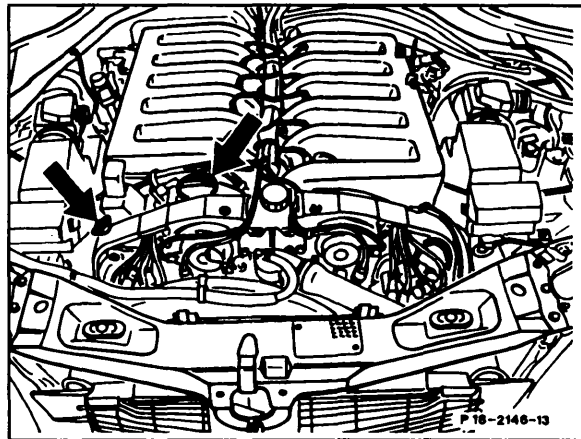

- Install air duct (engine 116, 117 in model 126, engine 119 in models 124, 129, 140).

Specified SAE viscosity classes during continuous ambient temperatures

Following the SAE grades exactly according to the ambient air temperatures would result in frequent engine oil changes. The temperature ranges for the SAE grades should therefore be regarded as a guideline which may be exceeded for brief periods.



CAUTION!

SAE 10W single grade oils must not be used in engine 617.95.

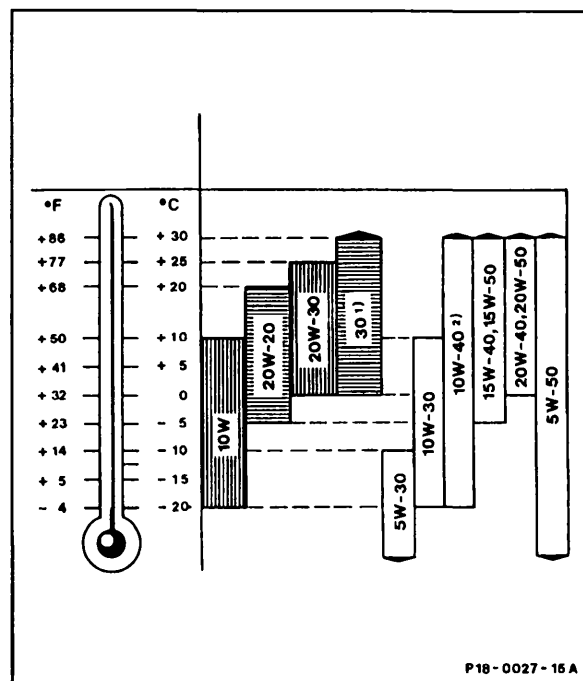

1) For continuous ambient temperatures above +30 °C (86 °F), SAE 40 can be used.

2) Except Turbodiesel engine 617.95

Oil capacity in liters

Engine	616, 617.91	617.95	617.95 (04/84)
Oil dipstick color code	red	white	ocher brown
Total capacity during oil and filter change	6.5	7.5	8.0
Oil pan	4.3	4.8	4.8

Torque specifications (Nm)

Oil pan drain plug	40
Mounting nuts, oil filter cover	25

Special tools

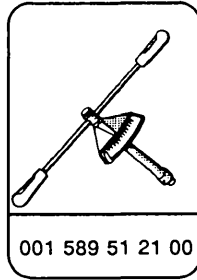
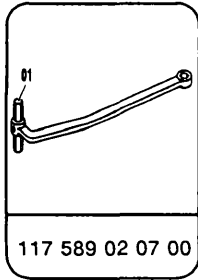

Due to the different sizes, the filter element and the rubber seal ring on the cap should not be exchanged with those on engines 601, 602 and 603.

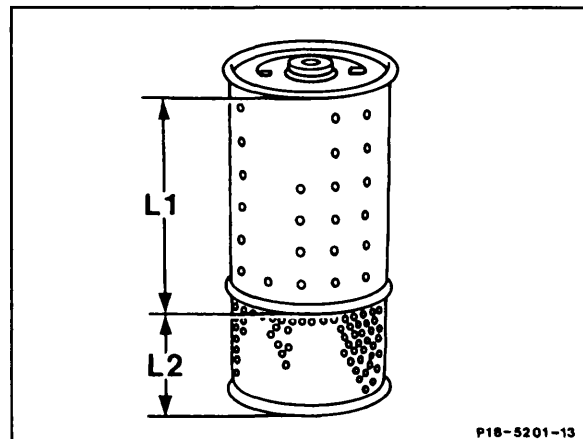

Engine 601,602,603	Engine 616,617
Dimension L1 113 mm	Dimension L1 131 mm
Dimension L2 49 mm	Dimension L2 55 mm

Prior to suctioning or draining engine oil, empty oil filter. For this purpose, loosen nuts (arrows) and remove cover.

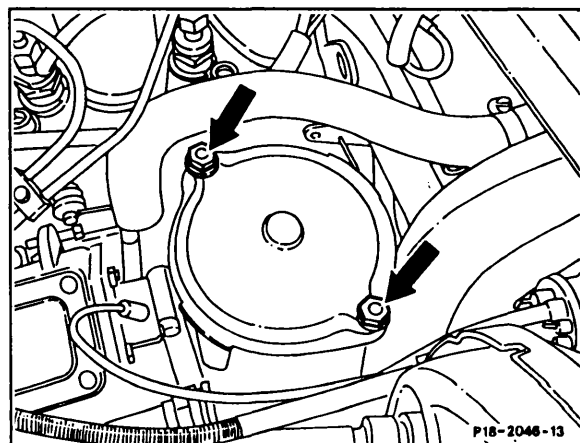

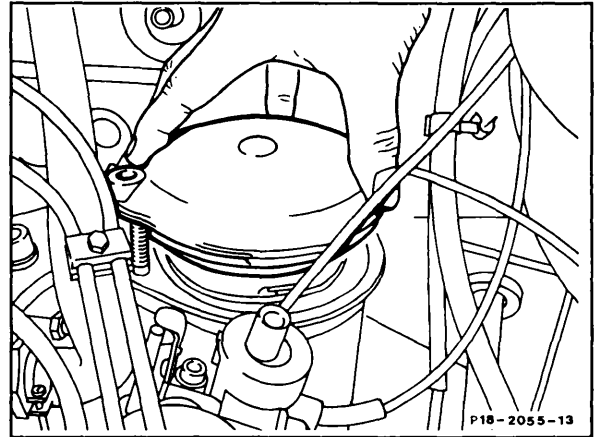

Suction engine oil via oil dipstick tube with engine at operating temperature.

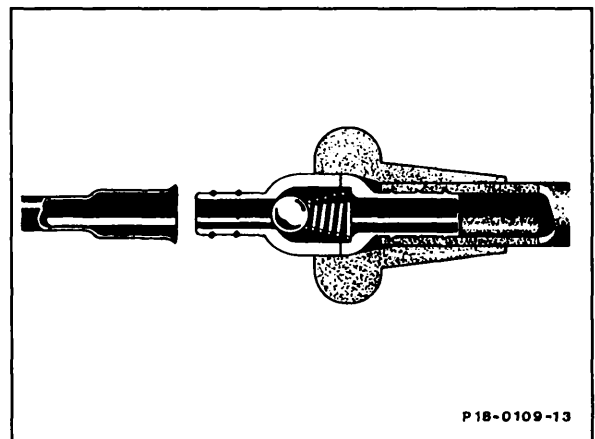

If no suction unit is available:

Drain engine oil from oil pan (arrow).

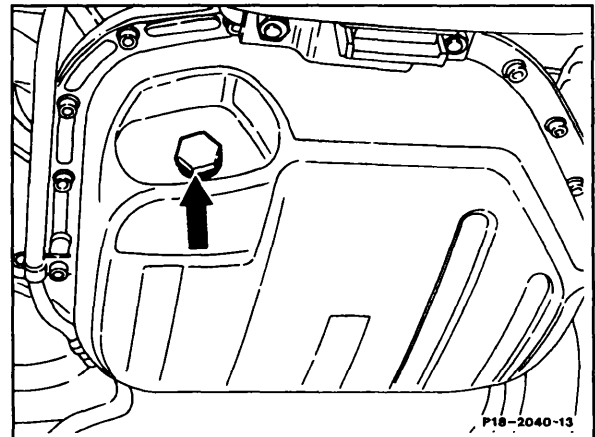

Replace filter element.

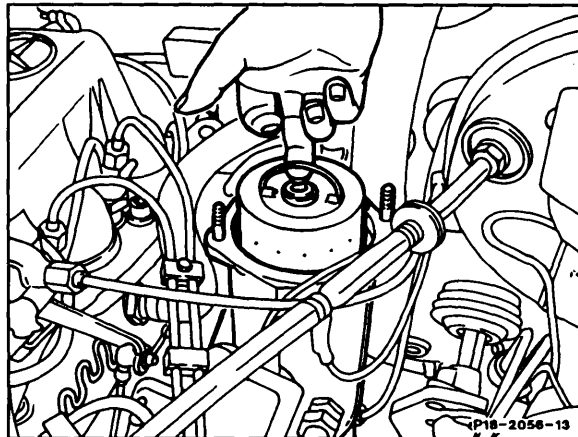

Replace rubber seal ring (1) on cover.

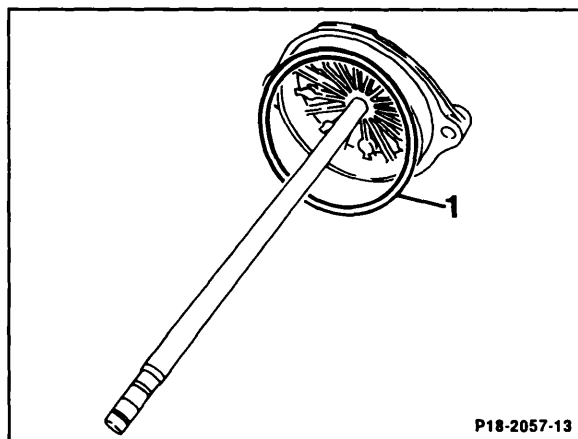

Check the oil port on the oil tube for foreign matter (arrow). If it is blocked, remove the foreign matter by hand. Then blow through the oil port with compressed air; air must noticeably come out of the bottom of the oil tube. If the oil port is not open or if no air comes out, replace oil filter cap and oil tube.

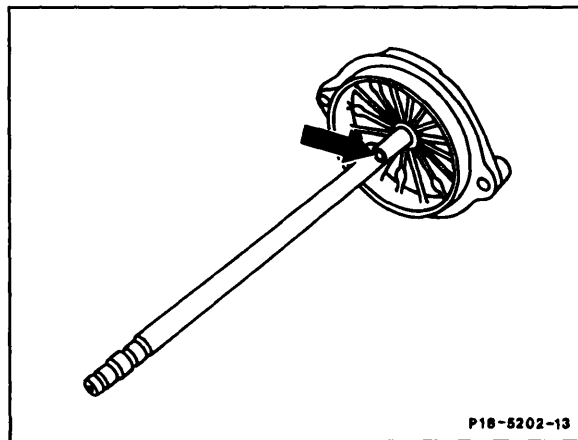

Tighten nuts to 25 Nm with torque wrench.

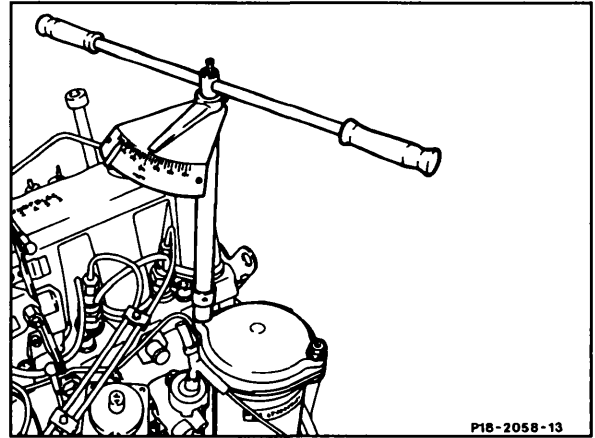

If oil has been drained from oil pan, replace seal ring on drain plug.

Tighten oil drain plug to 40 Nm.

Add engine oil.

Run engine and check for leaks.

Check oil approx. 2 min. after stopping engine at operating temperature.

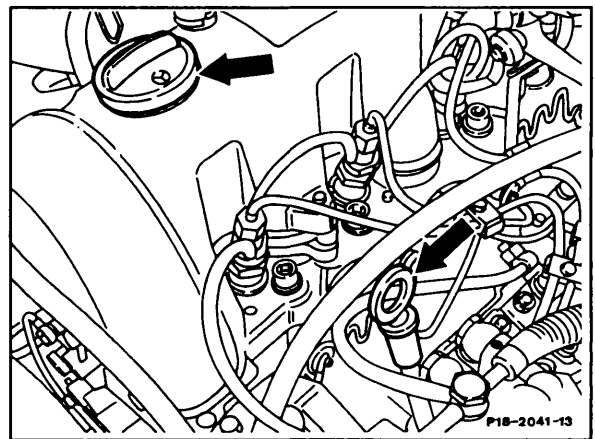

Specified SAE viscosity classes during continuous ambient temperatures

Following the SAE grades exactly according to the ambient air temperatures would result in frequent engine oil changes. The temperature ranges for the SAE grades should therefore be regarded as a guideline which may be exceeded for brief periods.

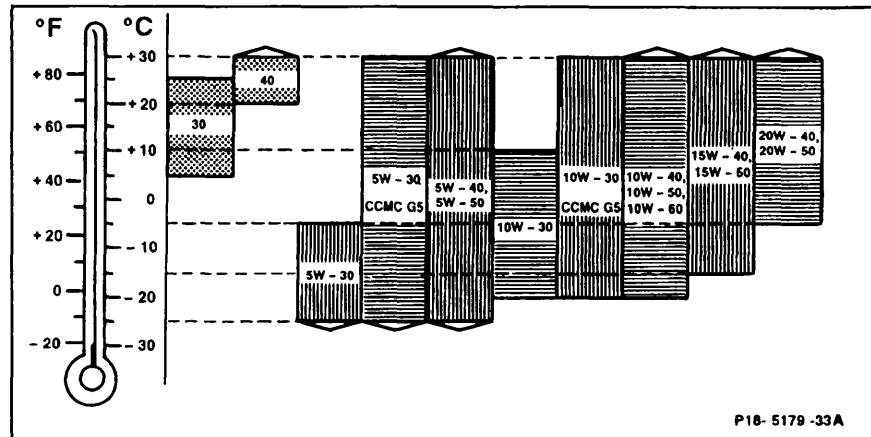

Oil capacity in liters

Engine	Model	Total capacity during oil and filter change	Oil dipstick identification		
			round handle	bottle opener shaped handle	Identification no.
601	201	6	black	-	-
602.91	201 (1986-88)	6.5	-	red black brown	60214
602.91	201 (1989)	7	-	green	-
602.96	124, 201	7	-	black green	-
603.96	124, 126	7.5	-	black	-
603.97	126	7.5	-	-	60316

Torque specifications (Nm)

Mounting nuts, oil filter cap	25
Oil pan drain plug 12 x 1.5 x 13	30
Oil pan drain plug 14 x 1.5 x 13	25
Return pipe in oil filter cover	25 (model 124 only)

Special tools

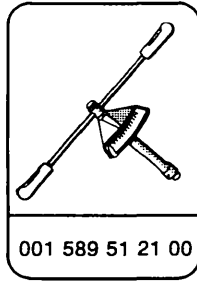
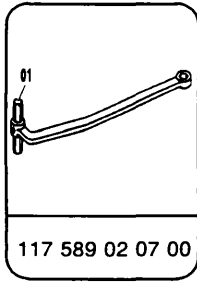

Due to the different sizes, the filter element and the rubber seal ring on the cap should not be exchanged with those on engines 615, 616 and 617.

On vehicles with air oil cooler (turbocharged engines) the oil need not be drained from the air oil cooler.

NOTE: Change engine oil only with engine at operating temperature.

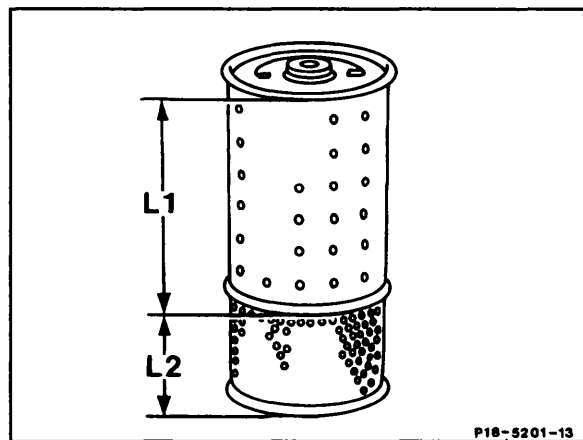

Engine 601,602,603

Dimension L1 113 mm
L2 49 mm

Engine 616,617

Dimension L1 131 mm
L2 55 mm

Empty oil filter prior to drawing off or draining engine oil. For this purpose, unscrew nuts (arrows) and remove cover.

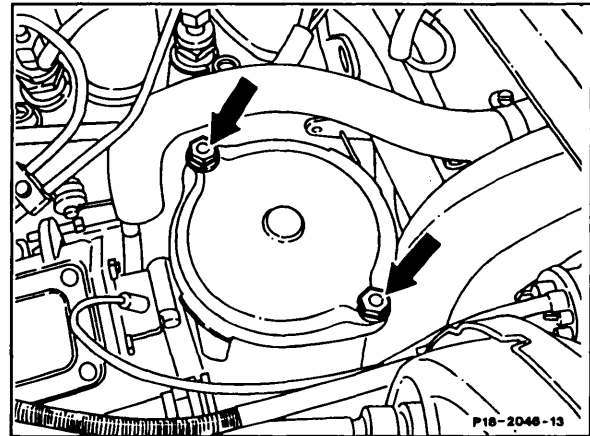

For this purpose, for reasons of available space, on engine 603 in model 124 (up to January 1986) loosen rubber gasket or sealing strip on unit partition as follows and pull slightly in upward direction.

With split rubber gasket

Pull off holding clamp (1).

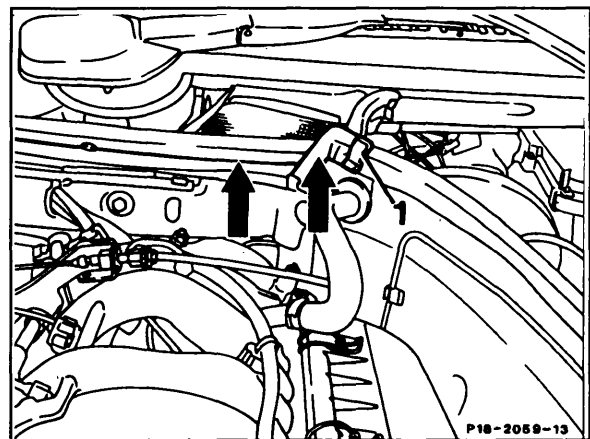

With one-piece rubber gasket

Unscrew screw (arrow).

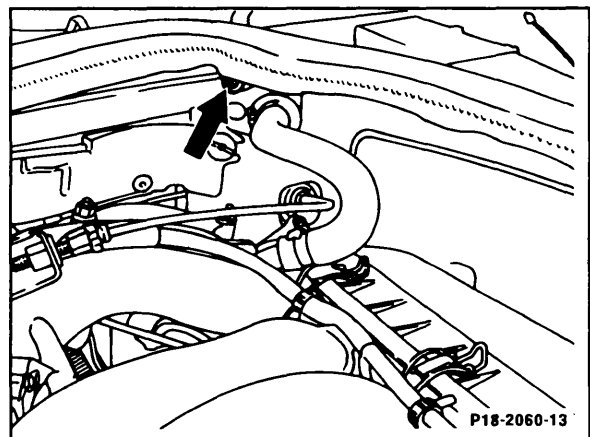

With two-piece oil filter cover

(starting February 1986, engine 603 in model 124)

Unscrew return pipe (276) and remove. Unscrew oil filter cover retaining nuts and remove cover.

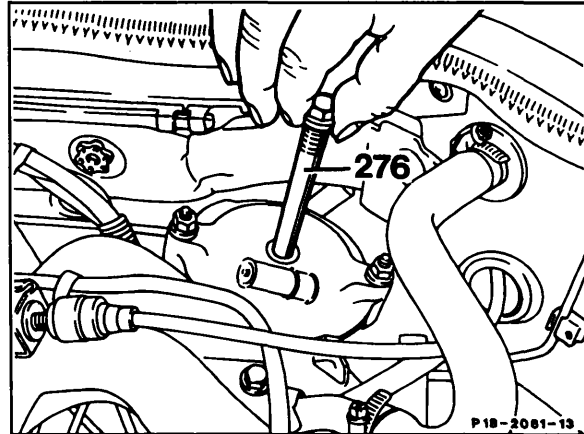

Suction engine oil via oil dipstick tube with engine at operating temperature.

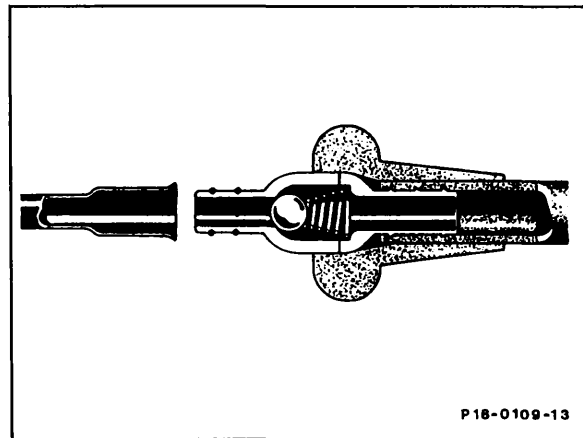

If no suction unit is available:

Remove lower noise encapsulation panel and install after finishing all maintenance work.

Drain engine oil from oil pan (arrow).

Note: The oil in air-oil cooler need not be drained.

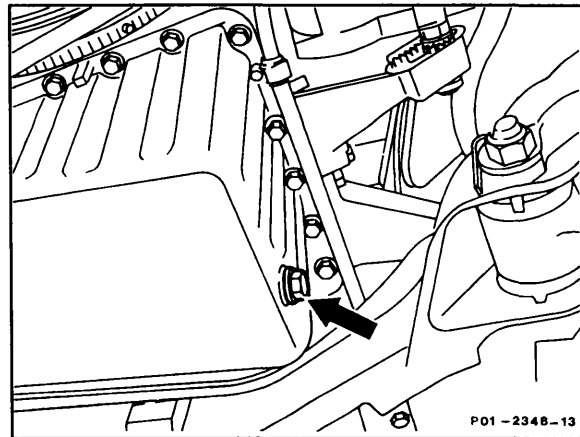

Replace filter element.

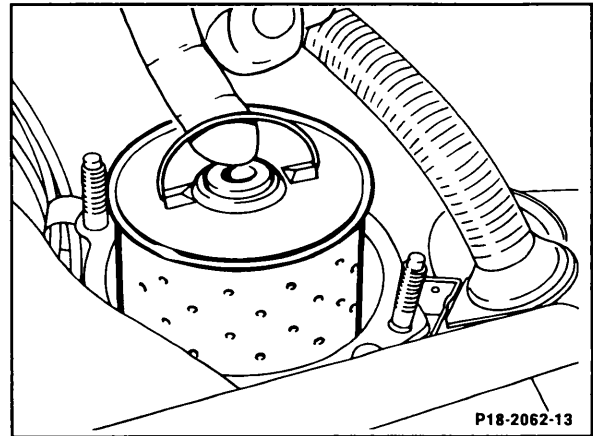

Replace rubber seal ring (1) on cover.

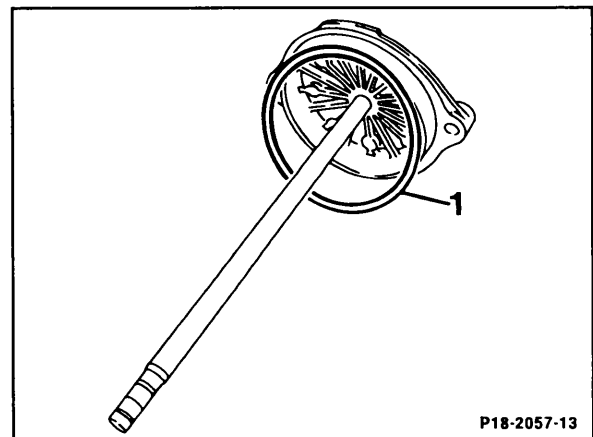

Check the oil port on the oil tube for foreign matter (arrow). If it is blocked, remove the foreign matter by hand. Then blow through the oil port with compressed air; air must noticeably come out of the bottom of oil tube. If the oil port is not open or if no air comes out, replace oil filter cap and oil tube.

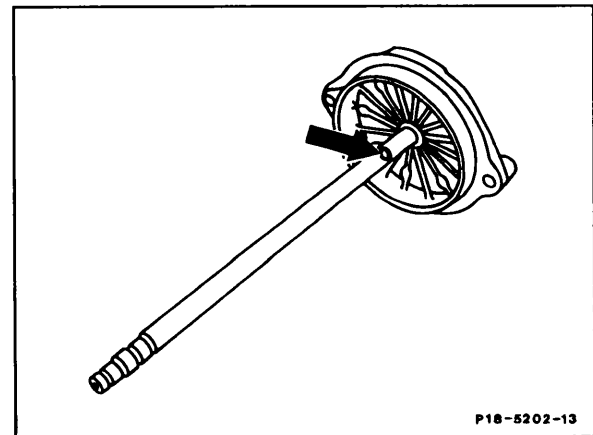

Tighten nuts to 25 Nm with a torque wrench.

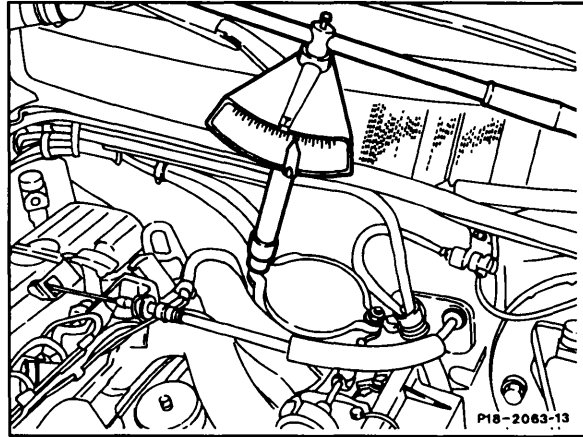

If the oil has been drained from oil pan, replace seal ring on oil drain plug.

Tighten oil drain plug to 30 or 25 Nm.

Add engine oil.

Run engine and check for leaks.

Check oil level approx. w minutes after stopping engine at operating temperature.

